

Acknowledgements:

The E158, HAPPEX, PREX, CREX and MOLLER Collaborations

Many thanks to numerous collaborators for ideas, photos, slides, text....

Parity-Violation in Electron-Electron Scattering



SLAC E158 and JLab MOLLER

Krishna Kumar

University of Massachusetts, Amherst

Electroweak Corrections at Current and Future Accelerators,
MITP Topical Workshop, Mainz, Germany
May 7, 2026

Outline

- **Introduction to Parity-Violating Electron Scattering (PVES)**
 - *One slide historical perspective*
- **The SLAC E158 Experiment**
 - *First demonstration of the running of the weak mixing angle*
- **The MOLLER Experiment**
 - *Experimental Goal*
 - *Status and Timeline*
- **Auxiliary MOLLER topics**
 - *PV electron-proton inelastic scattering at very forward angles and high W*
 - *The MOLLER Transverse Asymmetry Measurement*
- **Take Away Message**

*Introduction to
Parity-Violating
Electron Scattering
(PVES)*

Semi-Leptonic and Leptonic Weak Neutral Currents

at $Q^2 \ll M_Z^2$

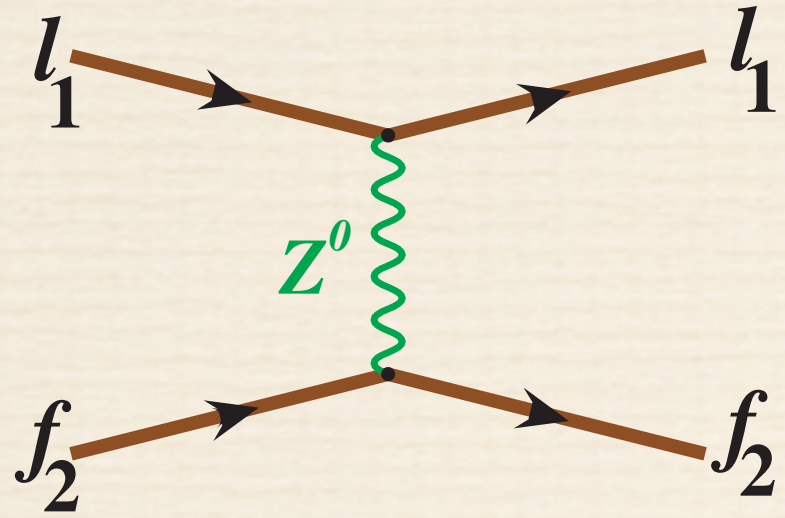

- ◆ Neutrino Scattering
- ◆ Weak-Electromagnetic Interference with Electrons

- opposite parity transitions in heavy atoms
- Spin-dependent electron scattering

Parity-violating Electron Scattering (PVES)

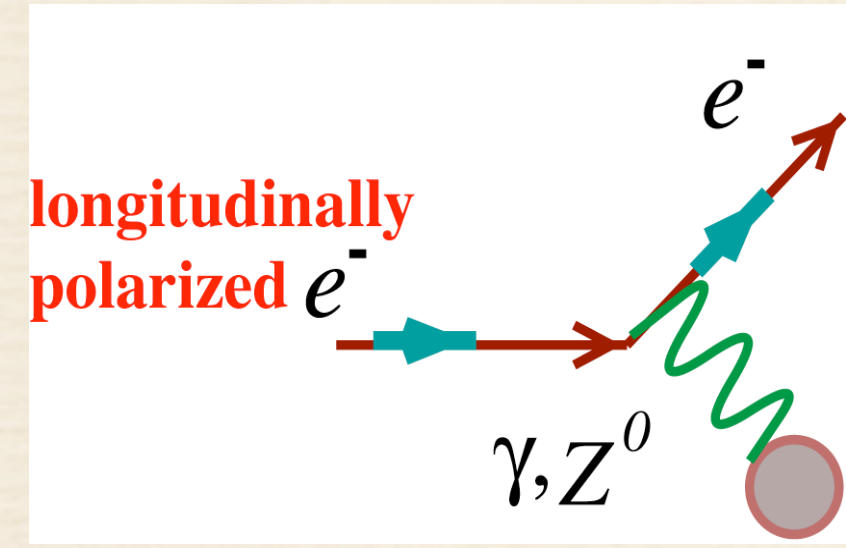

g_V's are functions of sin²θ_W

$$-A_{LR} = A_{PV} = \frac{\sigma_{\uparrow} - \sigma_{\downarrow}}{\sigma_{\uparrow} + \sigma_{\downarrow}} \sim \frac{A_{\text{weak}}}{A_{\gamma}} \sim \frac{G_F Q^2}{4\pi\alpha} (g_A^e g_V^T + \beta g_V^e g_A^T)$$

Weak Charge Q_w

$A_{PV} \sim 10^{-5} \cdot Q^2$ to $10^{-4} \cdot Q^2$

Specific choices of kinematics and target nuclei probe different physics:

- Mid-70s to late-80's: goal was to show $\sin^2\theta_W$ was the same as in neutrino scattering
- Early 90's to 2020's: target couplings probe novel aspects of hadron structure
 - ◆ strange quark form factors, neutron RMS radius of heavy nuclei
- Since late 90's: precision measurements with carefully chosen kinematics can probe physics at the multi-TeV scale via ultra-precise $\sin^2\theta_W$ measurements

Four Decades of PVES

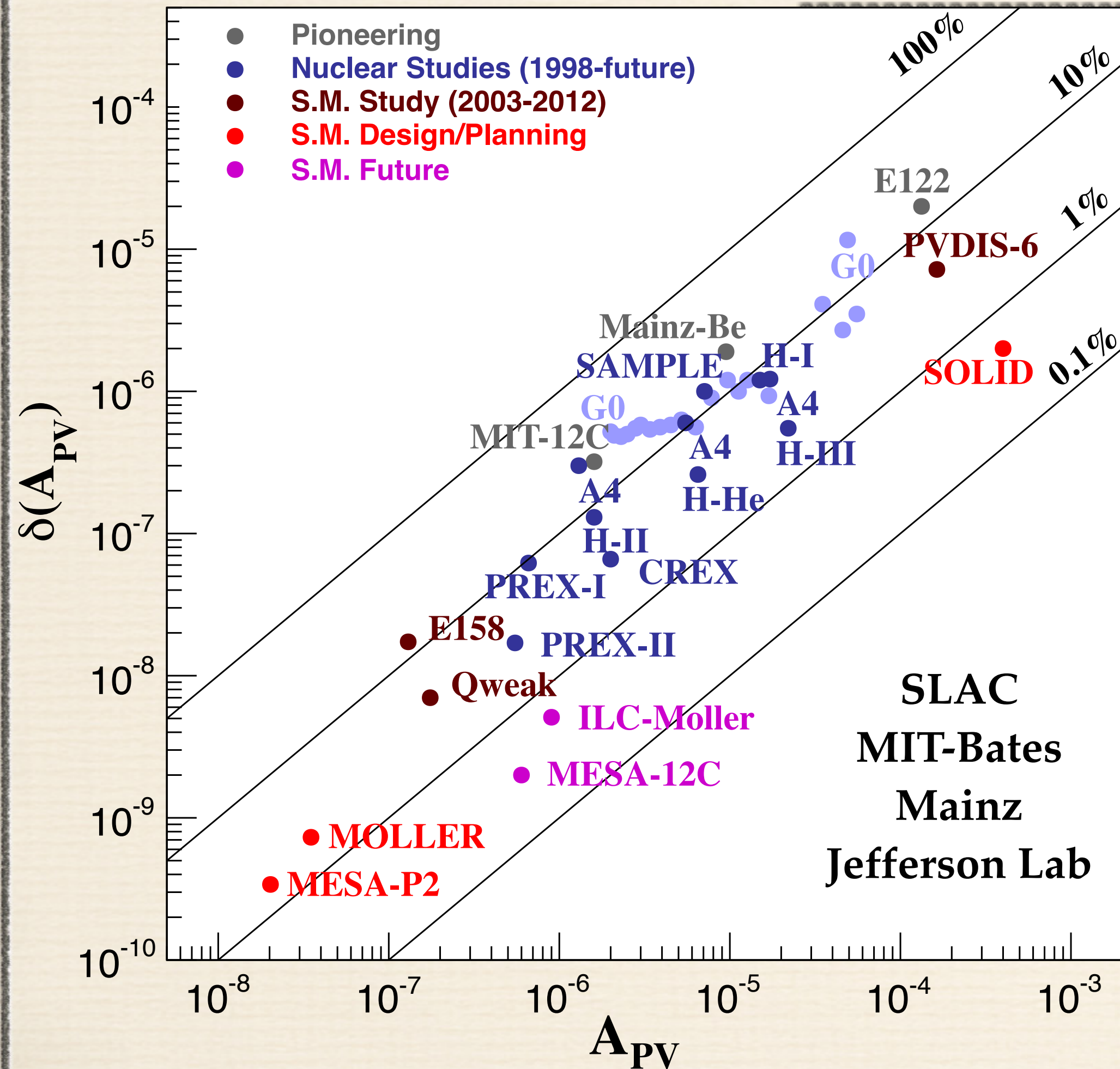

Parity-violating electron scattering has become a **precision tool**

- Beyond Standard Model Searches
- Strange quark form factors
- Neutron skin of a heavy nucleus
- QCD structure of the nucleon

State-of-the-art:

- sub-part per billion statistical reach and systematic control
- sub-1% normalization control

photocathodes, polarimetry, high power cryotargets, nanometer beam stability, precision beam diagnostics, low noise electronics, radiation hard detectors

*The SLAC E158
Experiment*

PV Electron-Electron (Møller) Scattering

A rare opportunity: a well-understood EW process below the scale of electroweak symmetry breaking that is purely leptonic

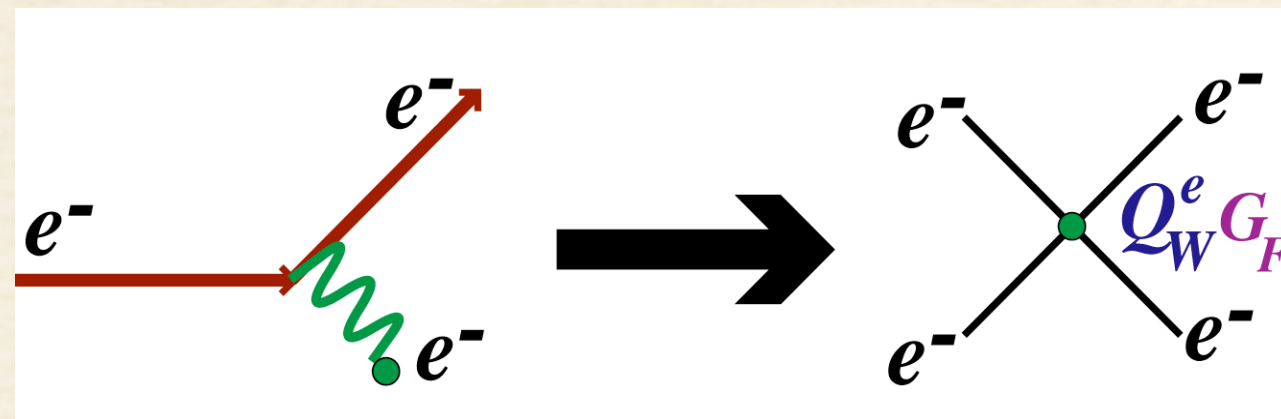

$$+ \frac{1}{\Lambda^2} \mathcal{L}_6$$

electron target:

$$Q_W = 1 - 4 \sin^2 \theta_W$$

$$\frac{\delta(Q_W)}{Q_W} \sim 10\% \implies \frac{\delta(\sin^2 \theta_W)}{\sin^2 \theta_W} \sim 0.5\%$$

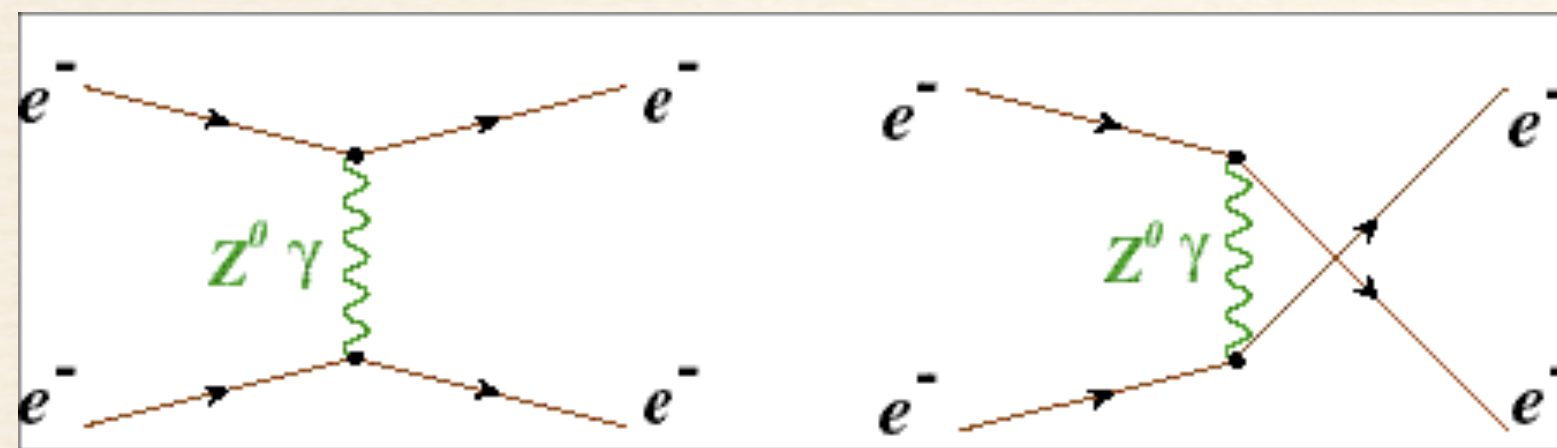

$$|A_\gamma + A_Z + A_{\text{new}}|^2 \rightarrow A_\gamma^2 \left[1 + 2 \left(\frac{A_Z}{A_\gamma} \right) + 2 \left(\frac{A_{\text{new}}}{A_\gamma} \right) \right]$$

$$A_{PV} \approx 8 \times 10^{-8} E_{\text{beam}} (1 - 4 \sin^2 \theta_W)$$

$$Q^2 = 2m_e E_{\text{beam}}$$

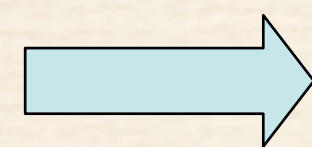

Tiny!



SLAC E158: 1997-2004

**$A_{PV} \sim 200$
parts per
billion**

End Station A at SLAC



Stanford Linear Accelerator Center

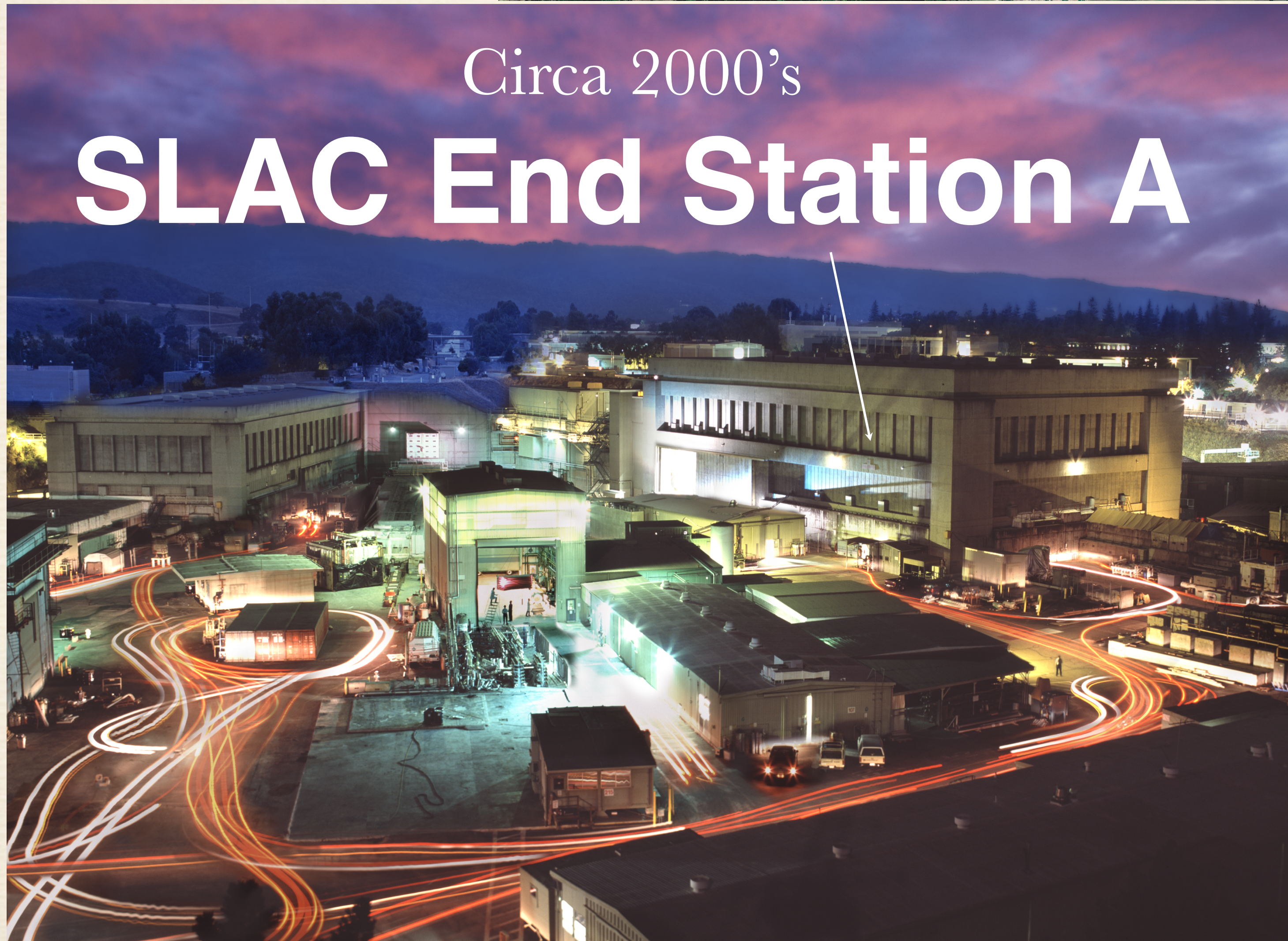

Circa 2000's

SLAC End Station A

Two Important Theory Papers launched E158



Annals of Physics

Volume 121, Issues 1–2, 1 September 1979, Pages 147-180



Parity violating asymmetries in polarized electron scattering ☆

Emanuel Derman¹, William J Marciano

TTP95-14, [hep-ph/9507420](https://arxiv.org/abs/hep-ph/9507420)

Electroweak Radiative Corrections To Polarized Møller Scattering Asymmetries

Andrzej Czarnecki

*Institut für Theoretische Teilchenphysik, Universität Karlsruhe,
D-76128 Karlsruhe, Germany*

William J. Marciano

*Physics Department, Brookhaven National Laboratory,
Upton, New York 11973*

and

*Institute for Nuclear Theory, Box 351550,
University of Washington, Seattle, WA 98195-1550*

Goal: error small enough to probe TeV scale physics

SLAC E158

1997-2004

~ 10 ppb statistical error at highest E_{beam} , ~ 0.5% error on weak mixing angle

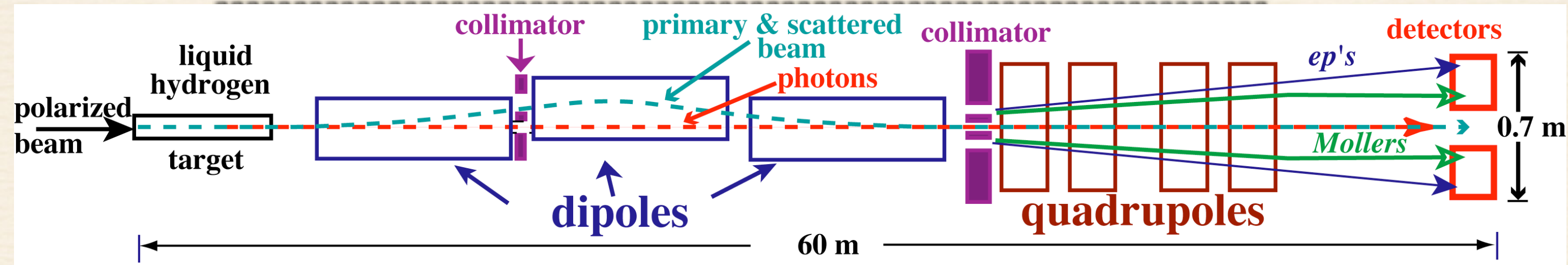

A large number of technical challenges

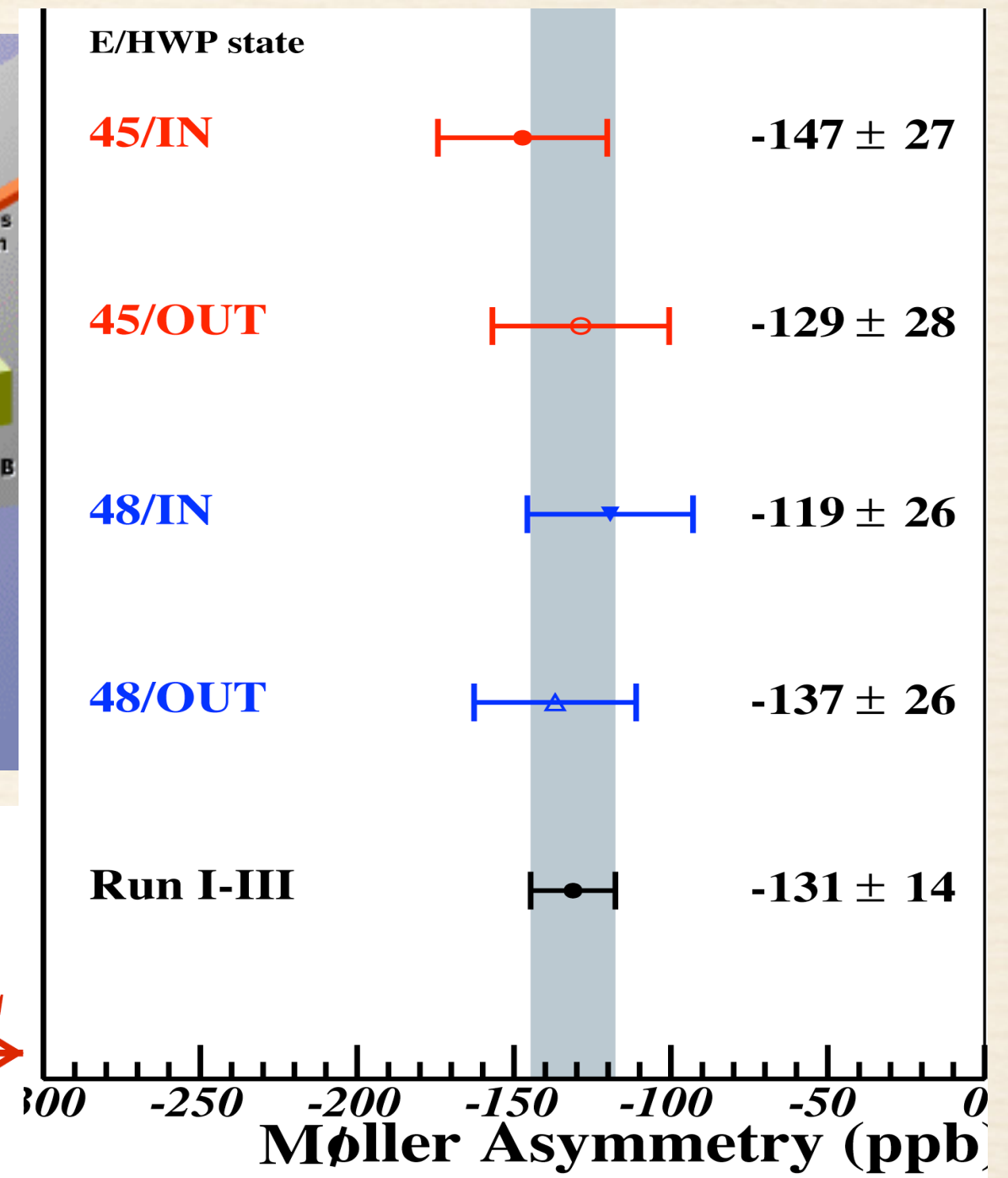
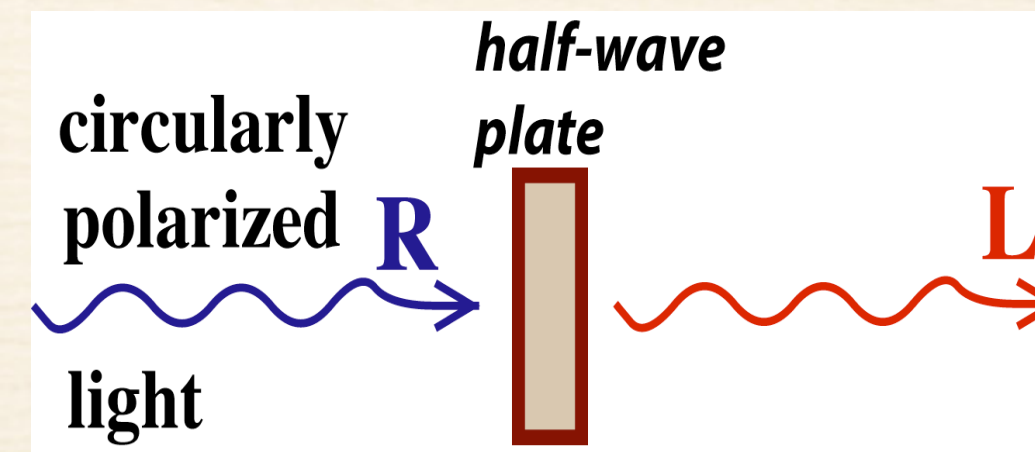
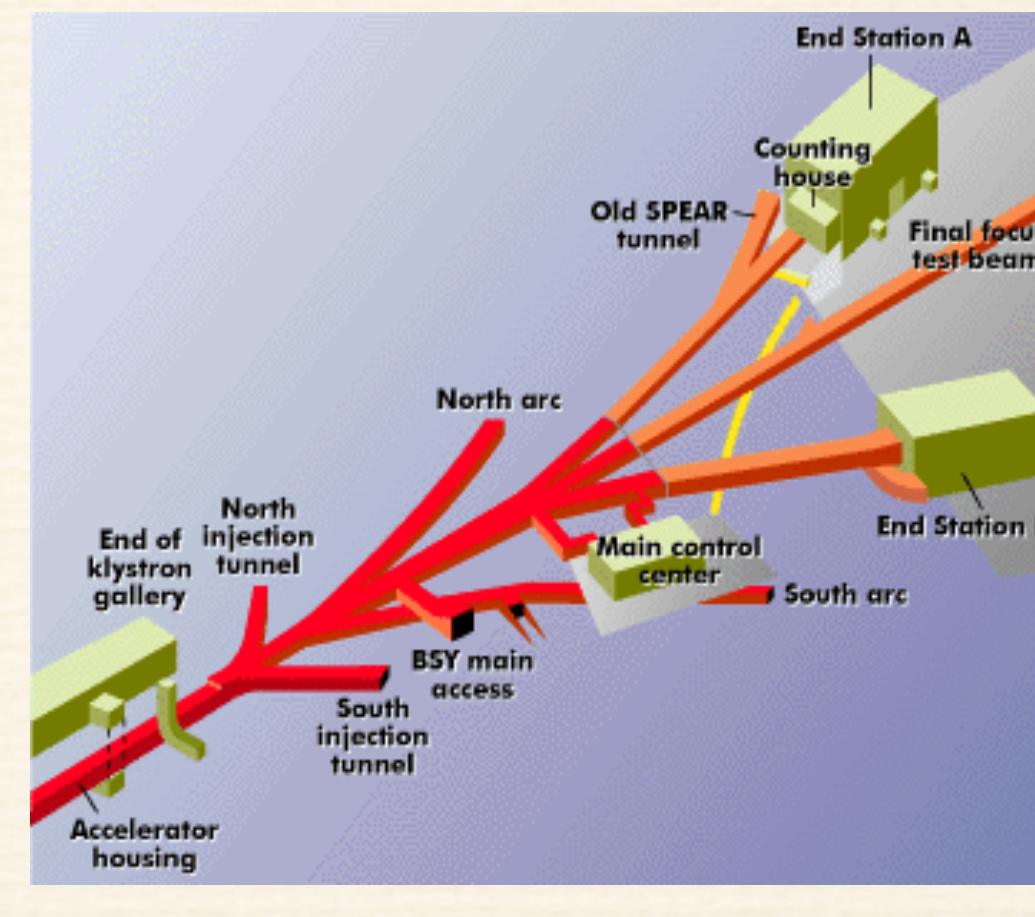

$$A_{PV} = (-131 \pm 14 \pm 10) \times 10^{-9}$$

Phys. Rev. Lett. **95** 081601 (2005)

Tree-level prediction: ~ 250 ppb

E158 Implications

Tree-level prediction: ~ 250 ppb

$$A_{PV} = (-131 \pm 14 \pm 10) \times 10^{-9}$$

E158 Implications

Final E158 Result

Phys. Rev. Lett. **95** 081601 (2005)

Tree-level prediction: ~ 250 ppb

$$A_{PV} = (-131 \pm 14 \pm 10) \times 10^{-9}$$

E158 Implications

Final E158 Result

Phys. Rev. Lett. **95** 081601 (2005)

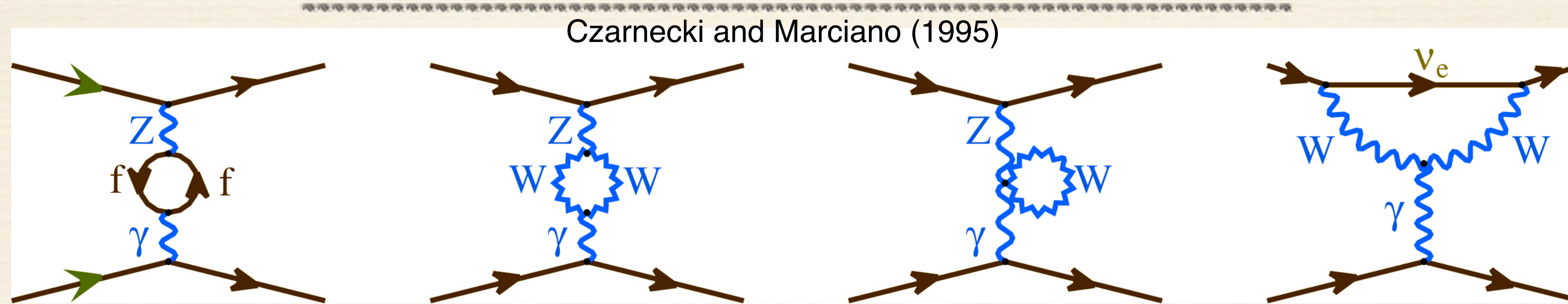

Tree-level prediction: ~ 250 ppb

$$A_{PV} = (-131 \pm 14 \pm 10) \times 10^{-9}$$

E158 Implications

Final E158 Result

Phys. Rev. Lett. **95** 081601 (2005)

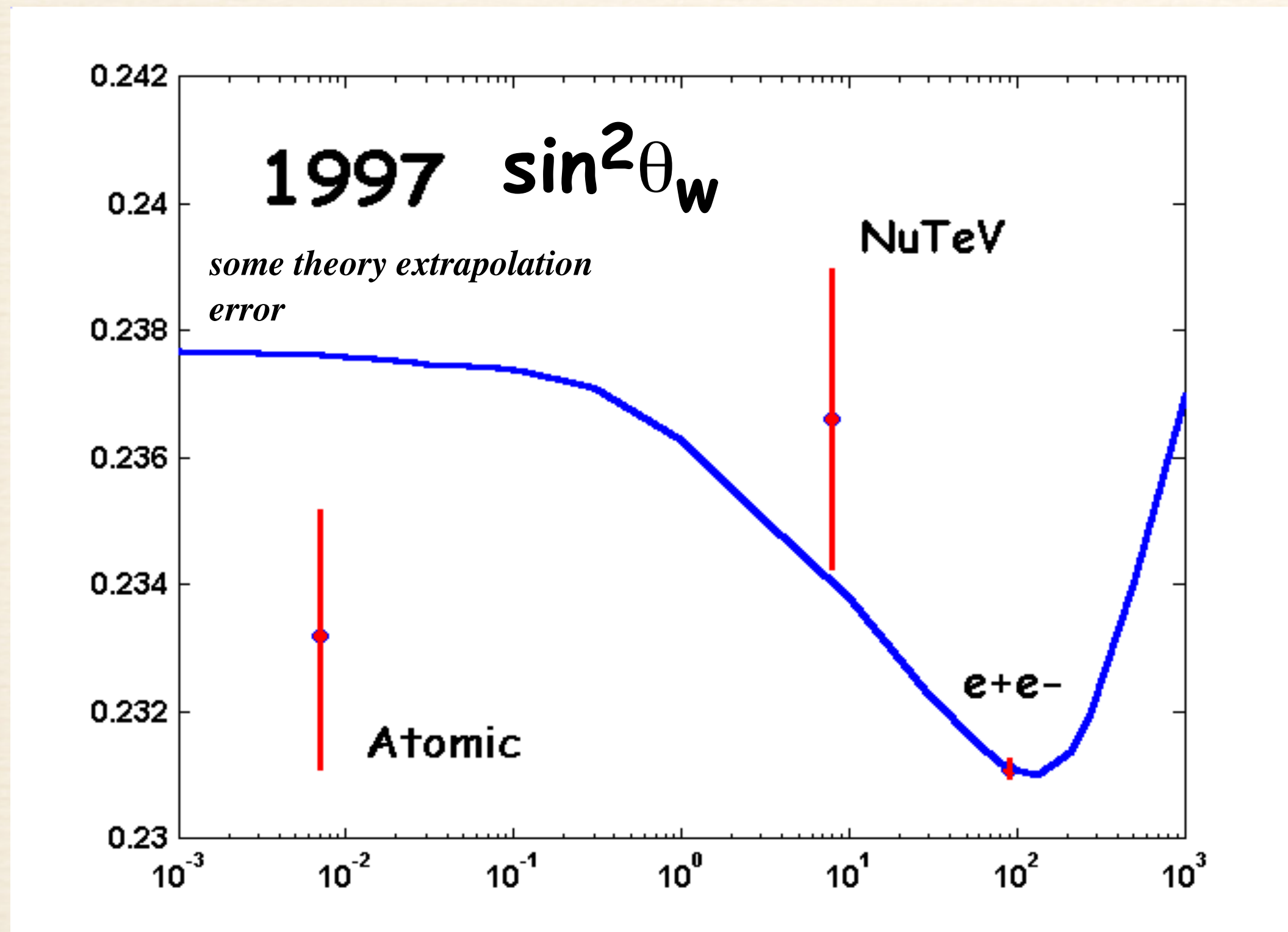
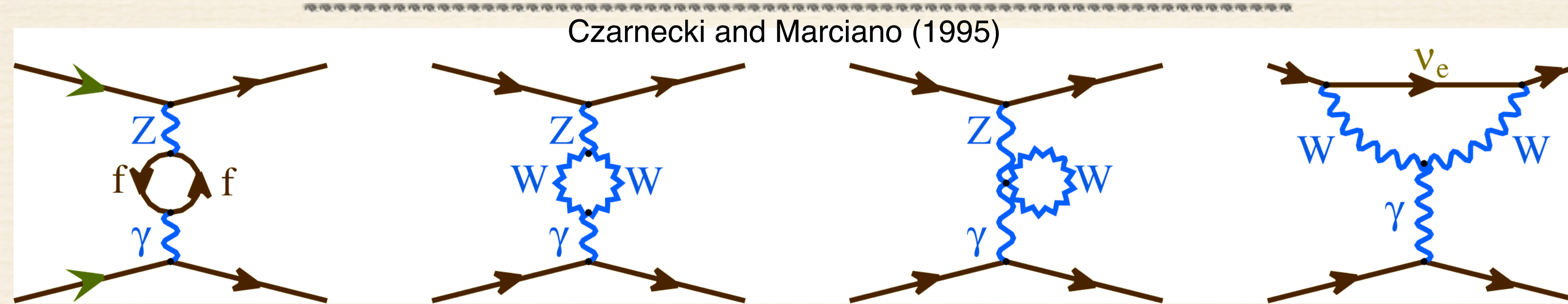

Tree-level prediction: ~ 250 ppb

$$A_{PV} = (-131 \pm 14 \pm 10) \times 10^{-9}$$

E158 Implications

Final E158 Result

Phys. Rev. Lett. **95** 081601 (2005)

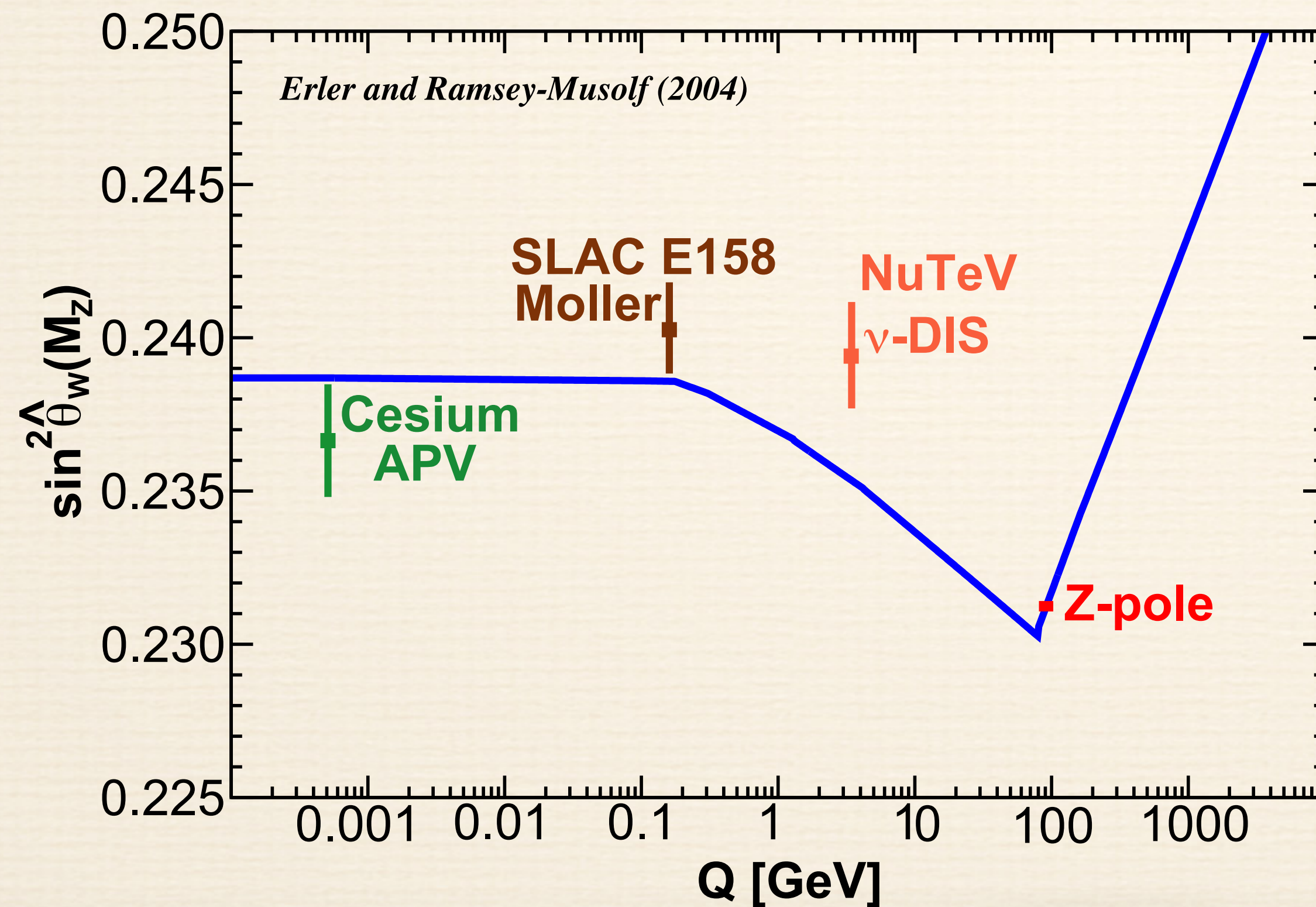
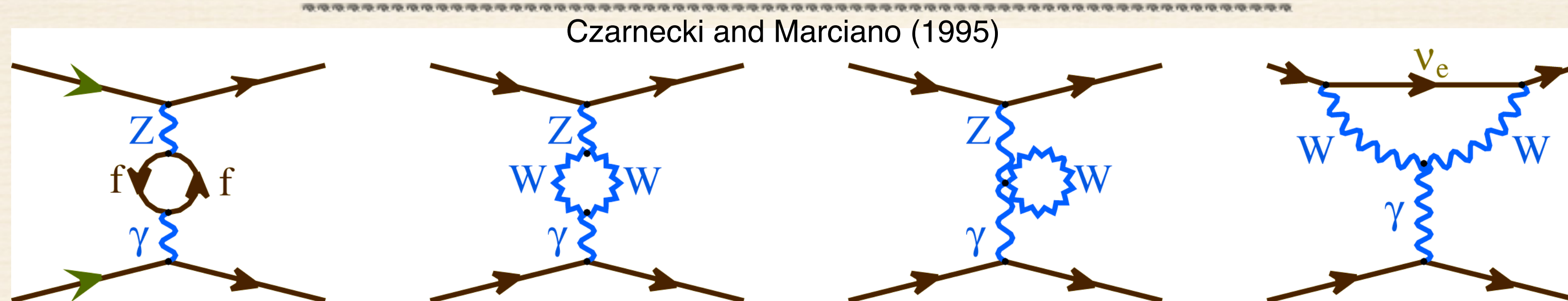

Tree-level prediction: ~ 250 ppb

$$A_{PV} = (-131 \pm 14 \pm 10) \times 10^{-9}$$

E158 Implications

Final E158 Result

Phys. Rev. Lett. **95** 081601 (2005)

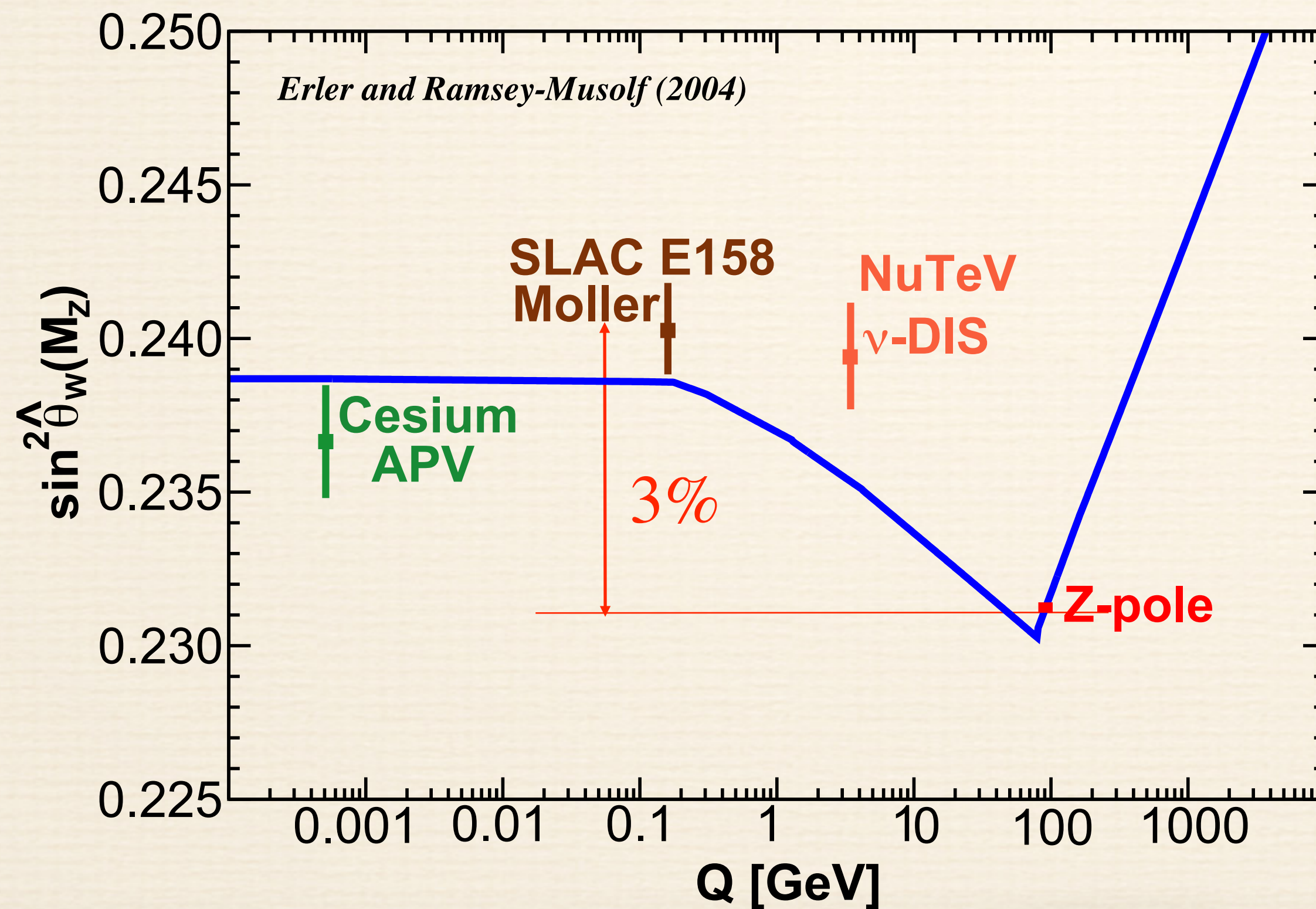
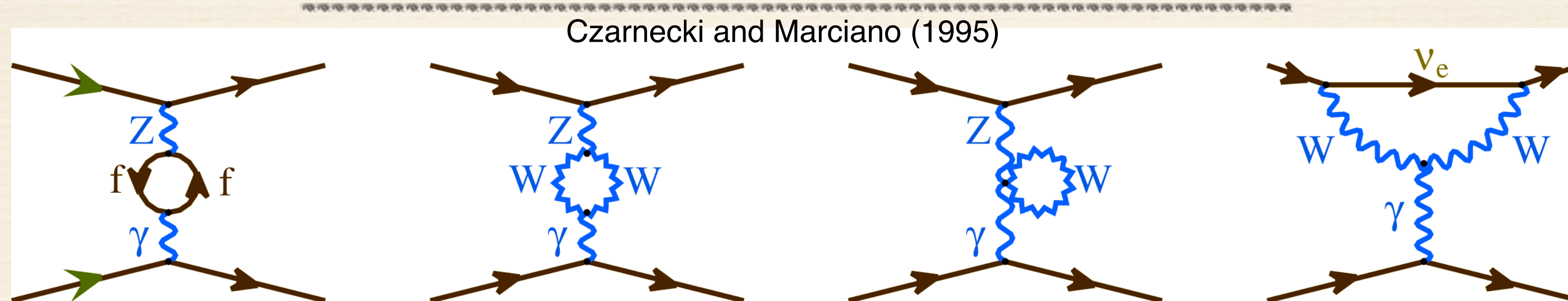

Tree-level prediction: ~ 250 ppb

$$A_{PV} = (-131 \pm 14 \pm 10) \times 10^{-9}$$

E158 Implications

Final E158 Result

Phys. Rev. Lett. **95** 081601 (2005)

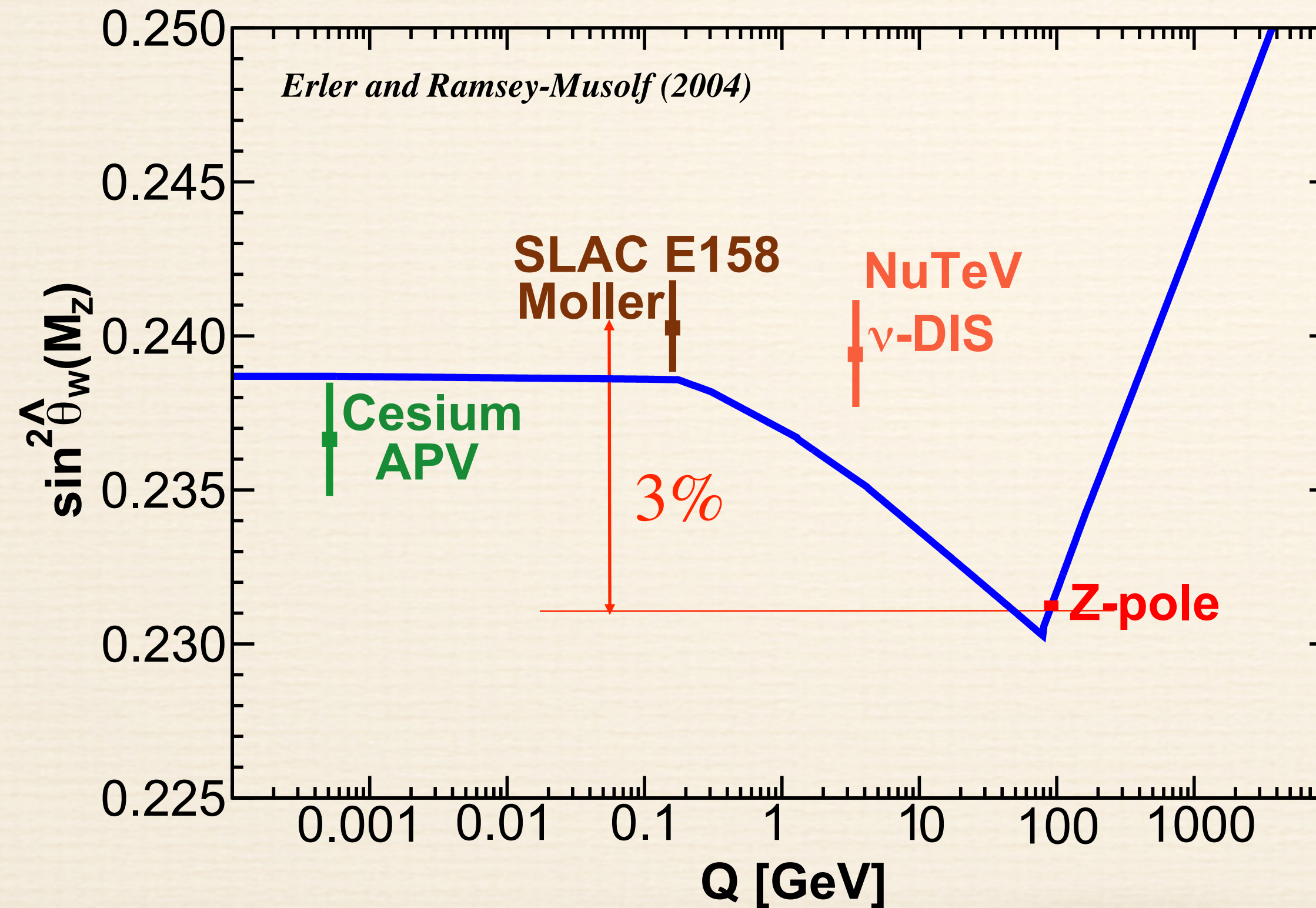

Limits on "New" Physics

LEP II
 95%
 $\left| \begin{matrix} e & e \\ \text{R} & \text{R} \end{matrix} \right|^2 + \left| \begin{matrix} e & e \\ \text{L} & \text{L} \end{matrix} \right|^2$
 17 TeV

Fermilab
 q e
 q e
 Z'
 0.8 TeV

doubly charged scalar exchange
 Δ
 $0.01 \cdot G_F$

E158

$\left| \begin{matrix} e & e \\ \text{R} & \text{R} \end{matrix} \right|^2 - \left| \begin{matrix} e & e \\ \text{L} & \text{L} \end{matrix} \right|^2$
 16 TeV

e^- e^-
 Z'
 e^- e^-
 1.0 TeV (Z_χ)

e^- e^-
 Δ
 e^- e^-

Electrons are not ambidextrous

Andrzej Czarnecki and William J. Marciano

The best low-energy measurement yet obtained of the electroweak mixing angle — a central parameter of the standard model of particle physics — is the last hurrah for Stanford's powerful two-mile linear accelerator.

Tree-level prediction: ~ 250 ppb

E158 Implications

Phys. Rev. Lett. 95 081601 (2005)

$$A_{PV} = (-131 \pm 14 \pm 10) \times 10^{-9}$$

Final E158 Result

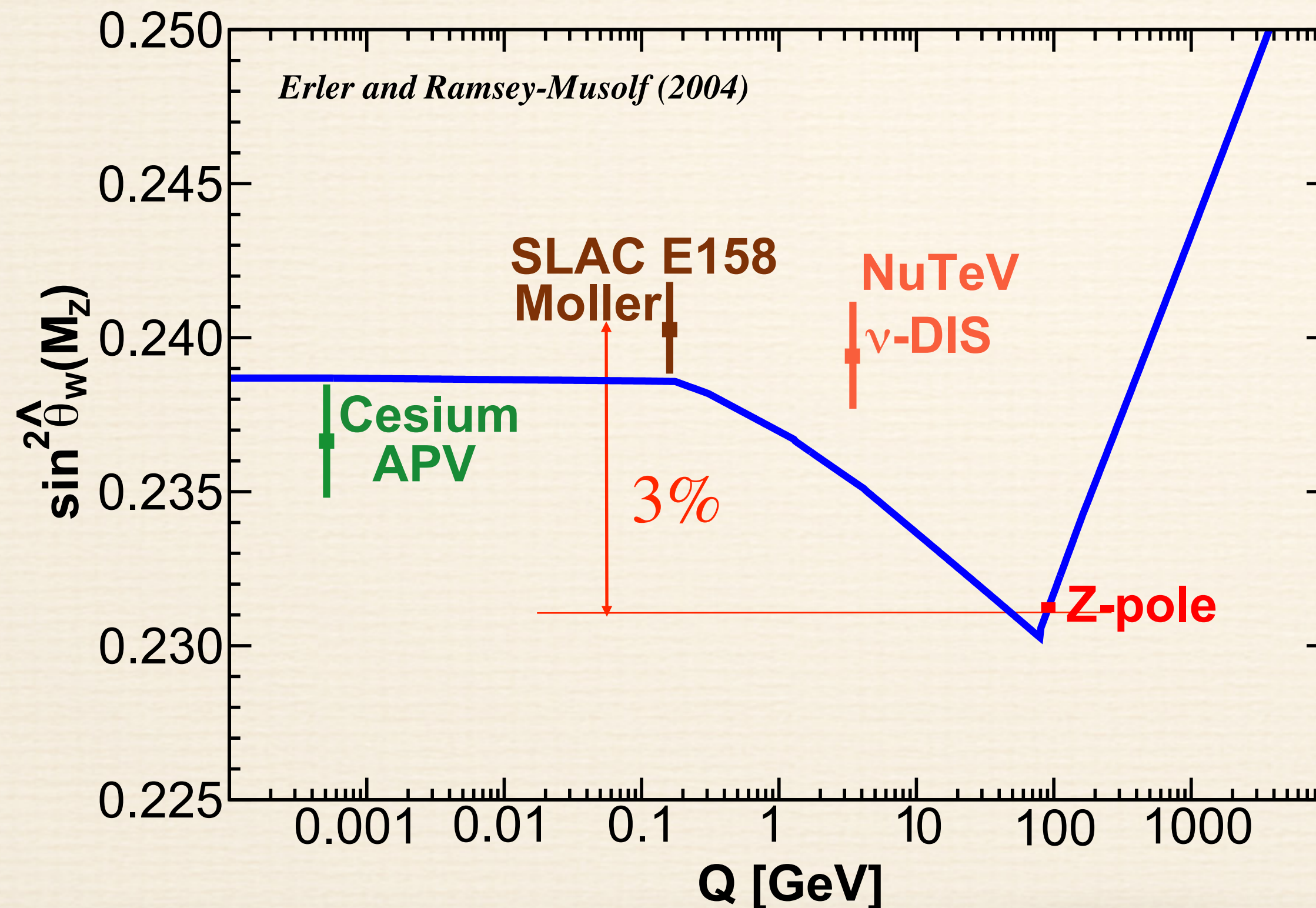

Limits on "New" Physics

LEP II
 $\left| \begin{matrix} e & e \\ \text{R} & \text{R} \end{matrix} \right|^2 + \left| \begin{matrix} e & e \\ \text{L} & \text{L} \end{matrix} \right|^2$
 17 TeV
 95%

Fermilab
 $q \begin{matrix} \diagup & \diagdown \\ & \text{Z}' \\ \diagdown & \diagup \end{matrix} e$
 0.8 TeV

doubly charged scalar exchange
 $0.01 \cdot G_F$

E158
 $\left| \begin{matrix} e & e \\ \text{R} & \text{R} \end{matrix} \right|^2 - \left| \begin{matrix} e & e \\ \text{L} & \text{L} \end{matrix} \right|^2$
 16 TeV

$e^- \begin{matrix} \diagup & \diagdown \\ & \text{Z}' \\ \diagdown & \diagup \end{matrix} e^-$
 1.0 TeV (Z_χ)

$e^- \begin{matrix} \diagup & \diagdown \\ & \Delta \\ \diagdown & \diagup \end{matrix} e^-$

Thumb Rule: Weak mixing angle must be measured to sub-0.5% precision

Neutral Current “Bookkeeping”

- Electron scattering weak charge measurement
- weak vector coupling of the target constituents
- **weak mixing angle extraction**

◆ Atomic Parity Violation: Cs-133

- ◆ future measurements challenging, theory improving

◆ Neutrino Scattering: NuTeV

- ◆ future measurements and theory challenging

◆ PV Møller Scattering: E158 at SLAC

- ◆ statistics limited, theory robust
- ◆ next generation: **MOLLER** (factor of 5 better)

◆ PV elastic e-p scattering: Qweak

- ◆ theory robust at low beam energy
- ◆ next generation: **P2** (factor of 3 better)

◆ PV Deep Inelastic Scattering: PVDIS

- ◆ theory robust for ^2H in valence quark region
- ◆ factor of 5 improvement: **SOLID**

Electroweak Radiative Corrections causes weak mixing angle to “run”

Czarnecki and Marciano (1995)

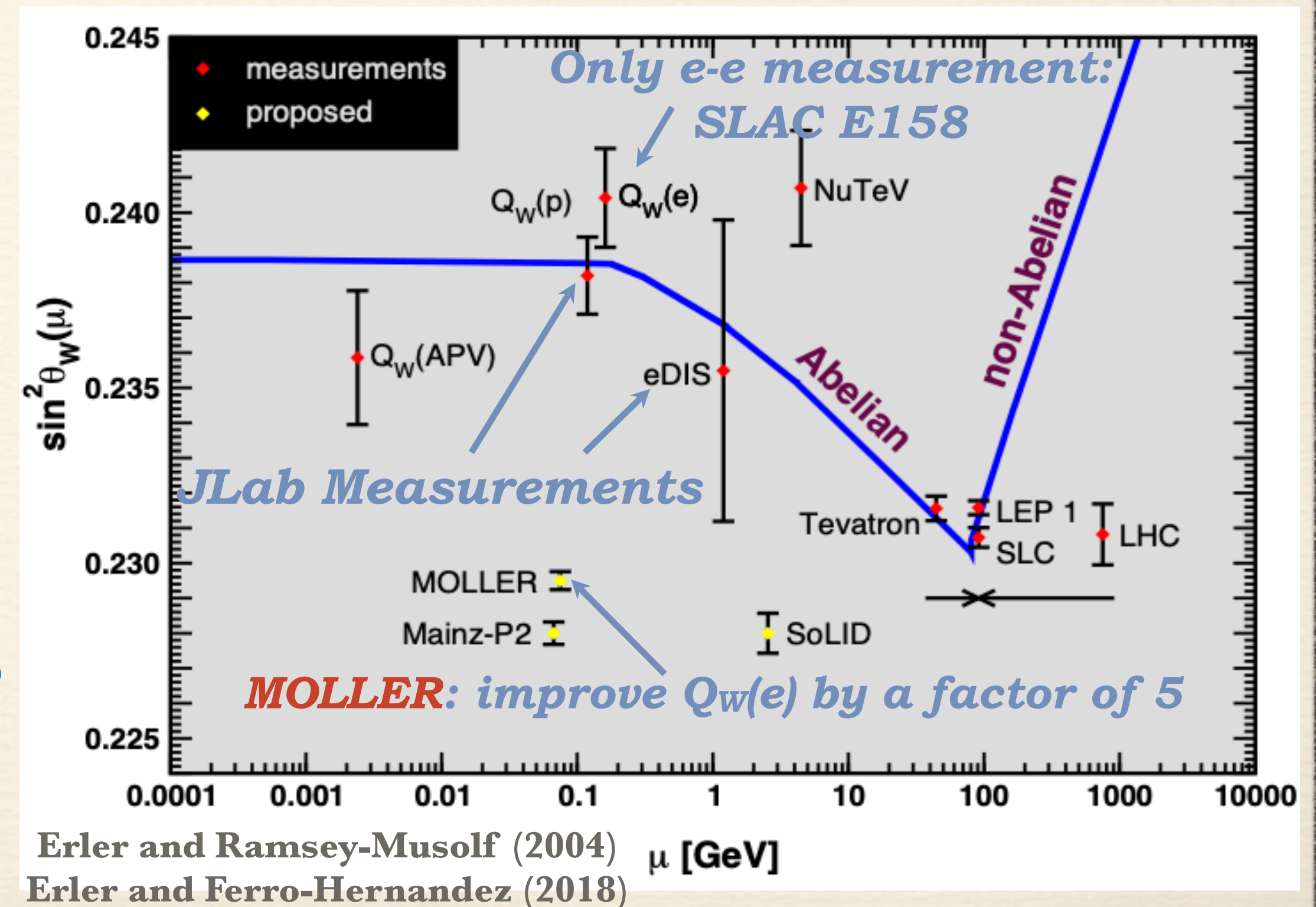
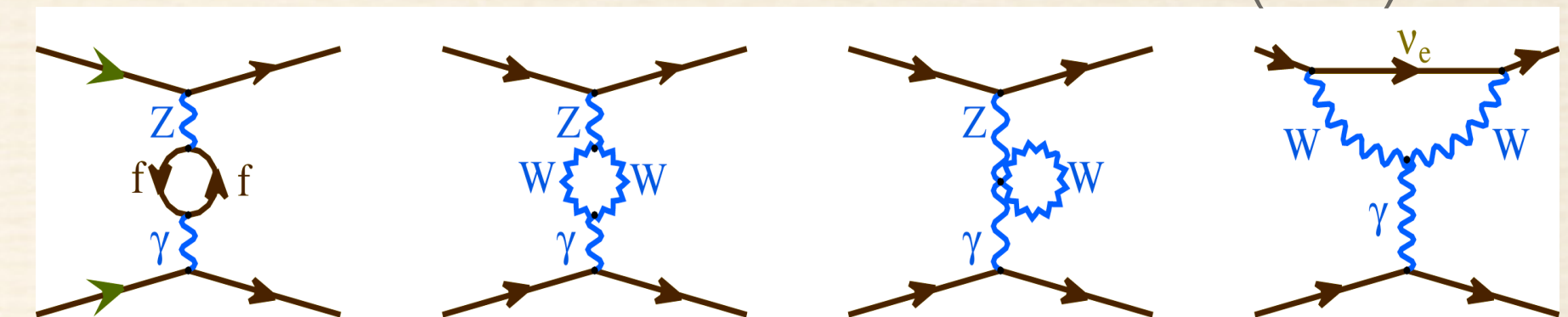

Weak Neutral Current (WNC) Couplings

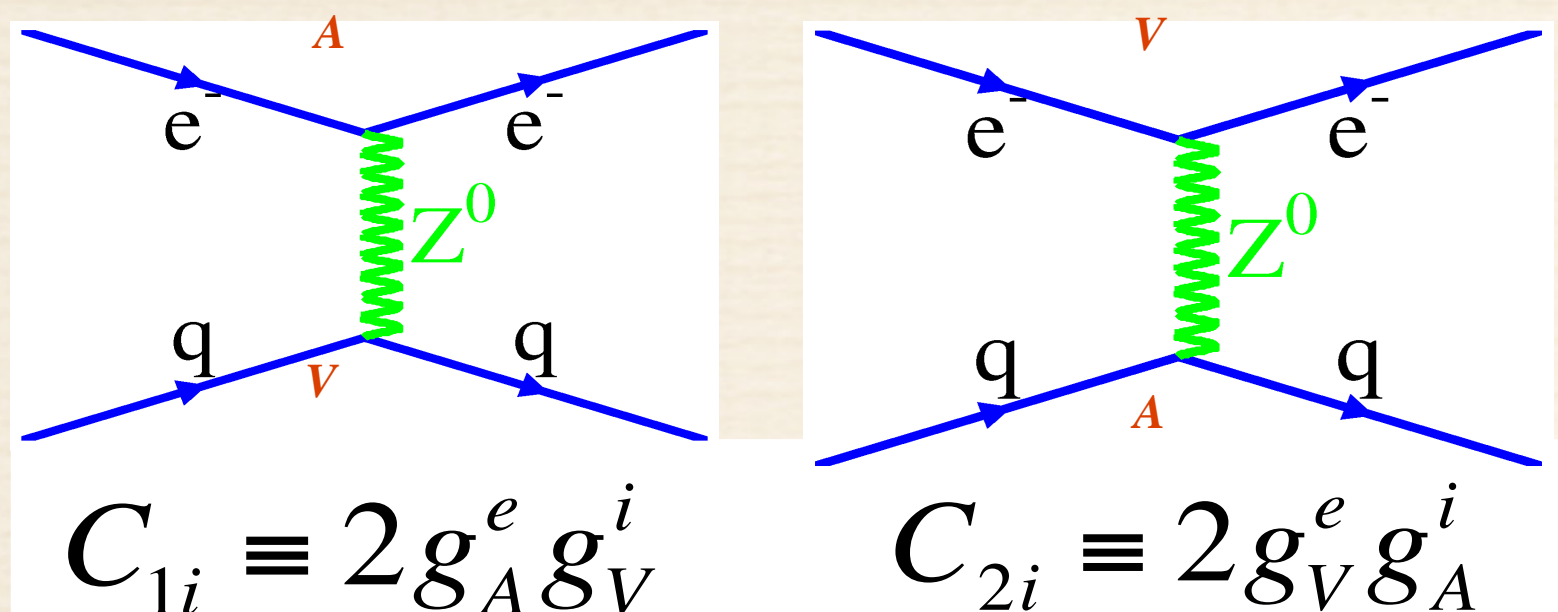

$$\mathcal{L}^{PV} = \frac{G_F}{\sqrt{2}} [\bar{e}\gamma^\mu \gamma_5 e (C_{1u}\bar{u}\gamma_\mu u + C_{1d}\bar{d}\gamma_\mu d) + \bar{e}\gamma^\mu e (C_{2u}\bar{u}\gamma_\mu \gamma_5 u + C_{2d}\bar{d}\gamma_\mu \gamma_5 d)] + C_{ee}(e\gamma^\mu \gamma_5 e \bar{e}\gamma_\mu e)$$

C_{1u}	$=$	$-\frac{1}{2} + \frac{4}{3} \sin^2 \theta_W$	\approx	-0.19
C_{1d}	$=$	$\frac{1}{2} - \frac{2}{3} \sin^2 \theta_W$	\approx	0.35
C_{2u}	$=$	$-\frac{1}{2} + 2 \sin^2 \theta_W$	\approx	-0.04
C_{2d}	$=$	$\frac{1}{2} - 2 \sin^2 \theta_W$	\approx	0.04

$$C_{1q} \propto (g_{RR}^{eq})^2 + (g_{RL}^{eq})^2 - (g_{LR}^{eq})^2 - (g_{LL}^{eq})^2$$



P2 ¹H and ¹²C
PV elastic e-N scattering,
Atomic parity violation

$$C_{2q} \propto (g_{RR}^{eq})^2 - (g_{RL}^{eq})^2 + (g_{LR}^{eq})^2 - (g_{LL}^{eq})^2$$



PV deep inelastic scattering

$$C_{ee} \propto (g_{RR}^{ee})^2 - (g_{LL}^{ee})^2$$



PV Møller scattering E158 and MOLLER

+ new physics

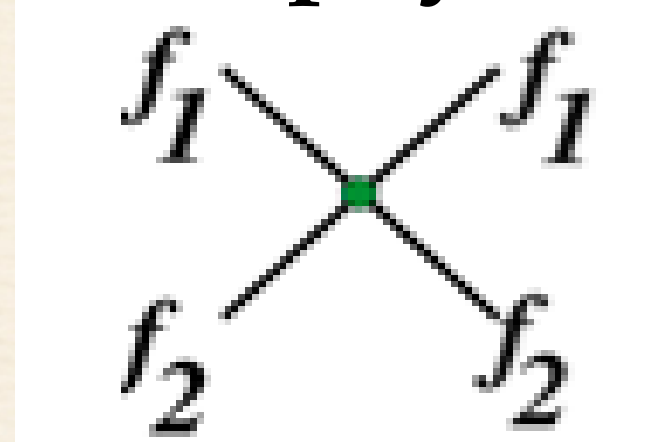

$$\mathcal{L}_{f_1 f_2} =$$

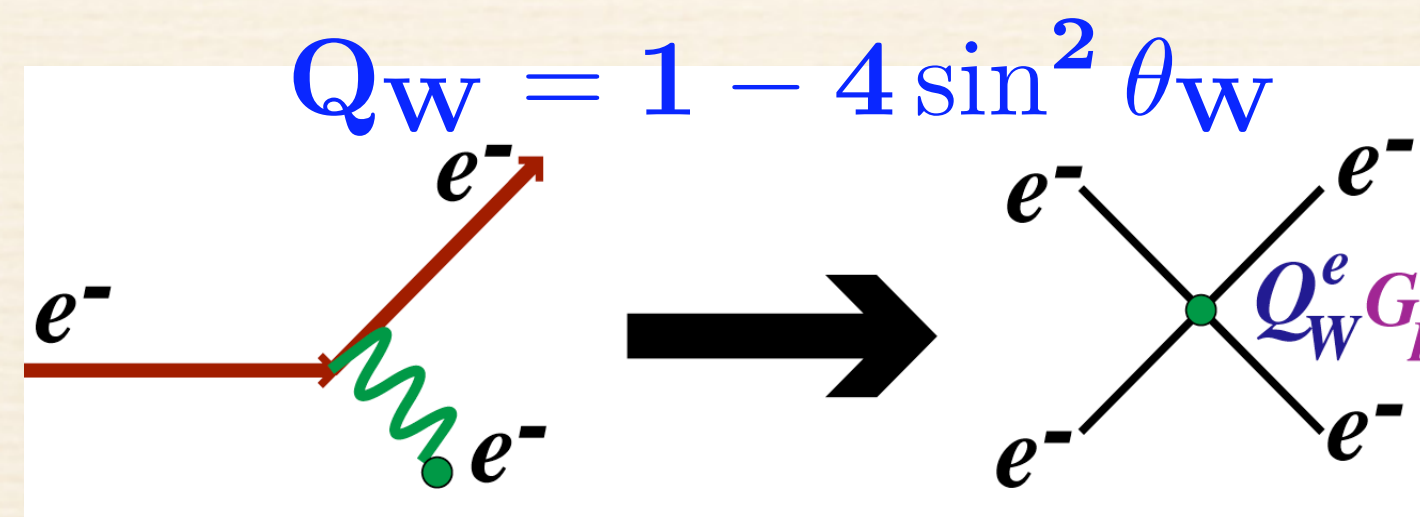
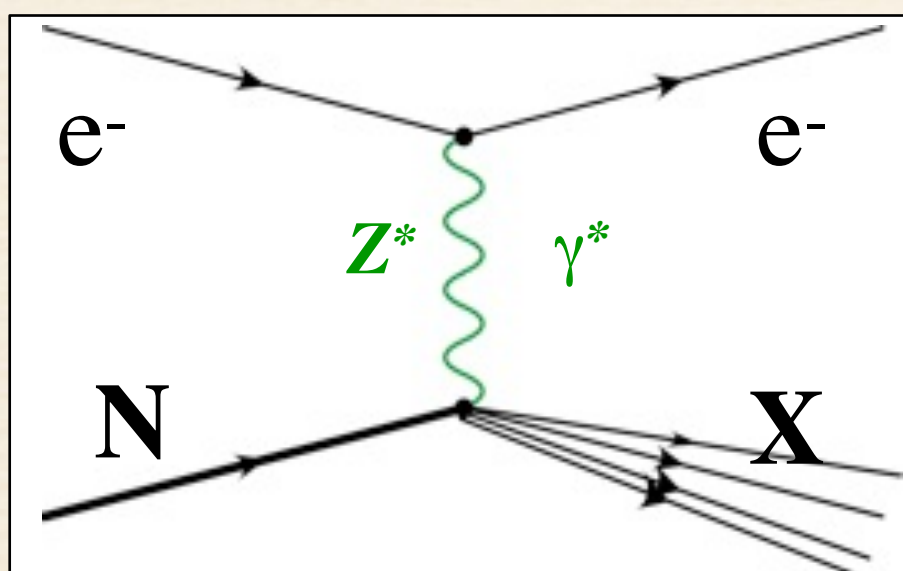
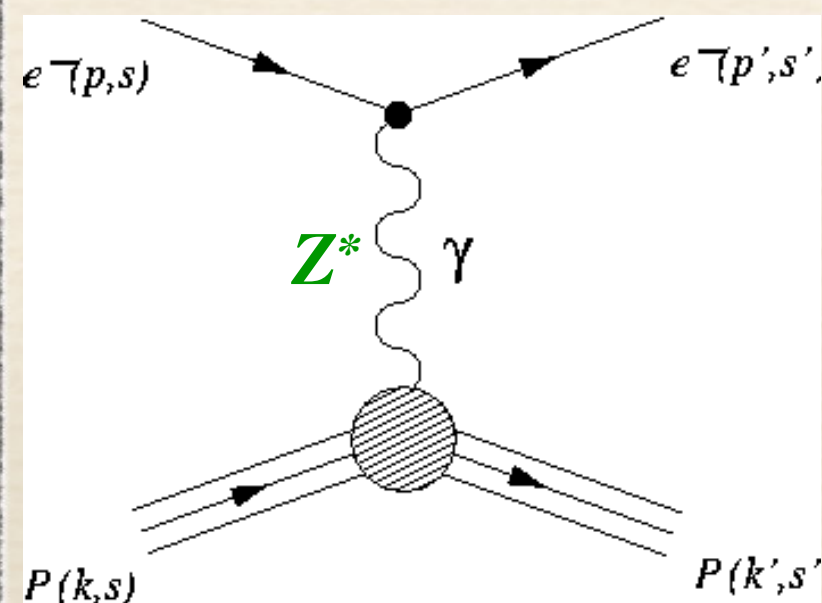

$$\sum_{i,j=L,R} \frac{(g_{ij}^{12})^2}{\Lambda_{ij}^2} \bar{f}_{1i} \gamma_\mu f_{1i} \bar{f}_{2j} \gamma_\mu f_{2j}$$

*The MOLLER
Experiment*

The MOLLER Sensitivity

11 GeV, 65 μA 90% beam polarization

$A_{PV} \sim 32$ ppb

$\delta(A_{PV}) \sim 0.8$ ppb

$\delta(Q_W^e) = \pm 2.1\%$ (stat.) $\pm 1.1\%$ (syst.)

A new experiment to measure parity-violating Møller scattering at Jefferson Lab

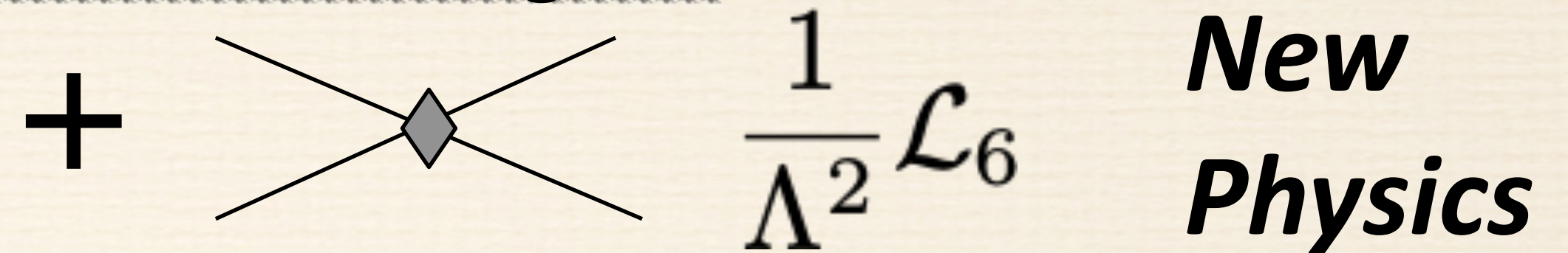

$\delta(\sin^2\theta_W) = \pm 0.00023$ (stat.) ± 0.00012 (syst.)

→ $\sim 0.1\%$

$$\frac{\Lambda}{\sqrt{|g_{RR}^2 - g_{LL}^2|}} = \frac{1}{\sqrt{\sqrt{2}G_F|\Delta Q_W^e|}} \simeq \frac{246.22 \text{ GeV}}{\sqrt{0.023Q_W^e}} = 7.5 \text{ TeV.}$$

Conventional Collider Contact Interaction Analysis: → $|g_{RR}^2 - g_{LL}^2| = 4\pi$

LEP200

Simultaneous fits to cross-sections and angular distributions

$\Lambda_{LL}^{ee} \sim 8.3$ TeV

95%

$\Lambda_{RR}^{ee} \sim 8.2$ TeV

C.L.

Limits

$\Lambda_{VV}^{ee} \sim 17.7$ TeV

MOLLER Reach

$\Lambda_{LL}^{ee} \sim 27$ TeV

$\Lambda_{RR-LL}^{ee} \sim 38$ TeV

LEP-200 insensitive

MOLLER is the only probe of new purely leptonic 6-dimensional operators with reach beyond LEP-200 until the next linear collider

Engineering Design and major acquisitions **complete** and **construction ongoing**

MOLLER Experiment

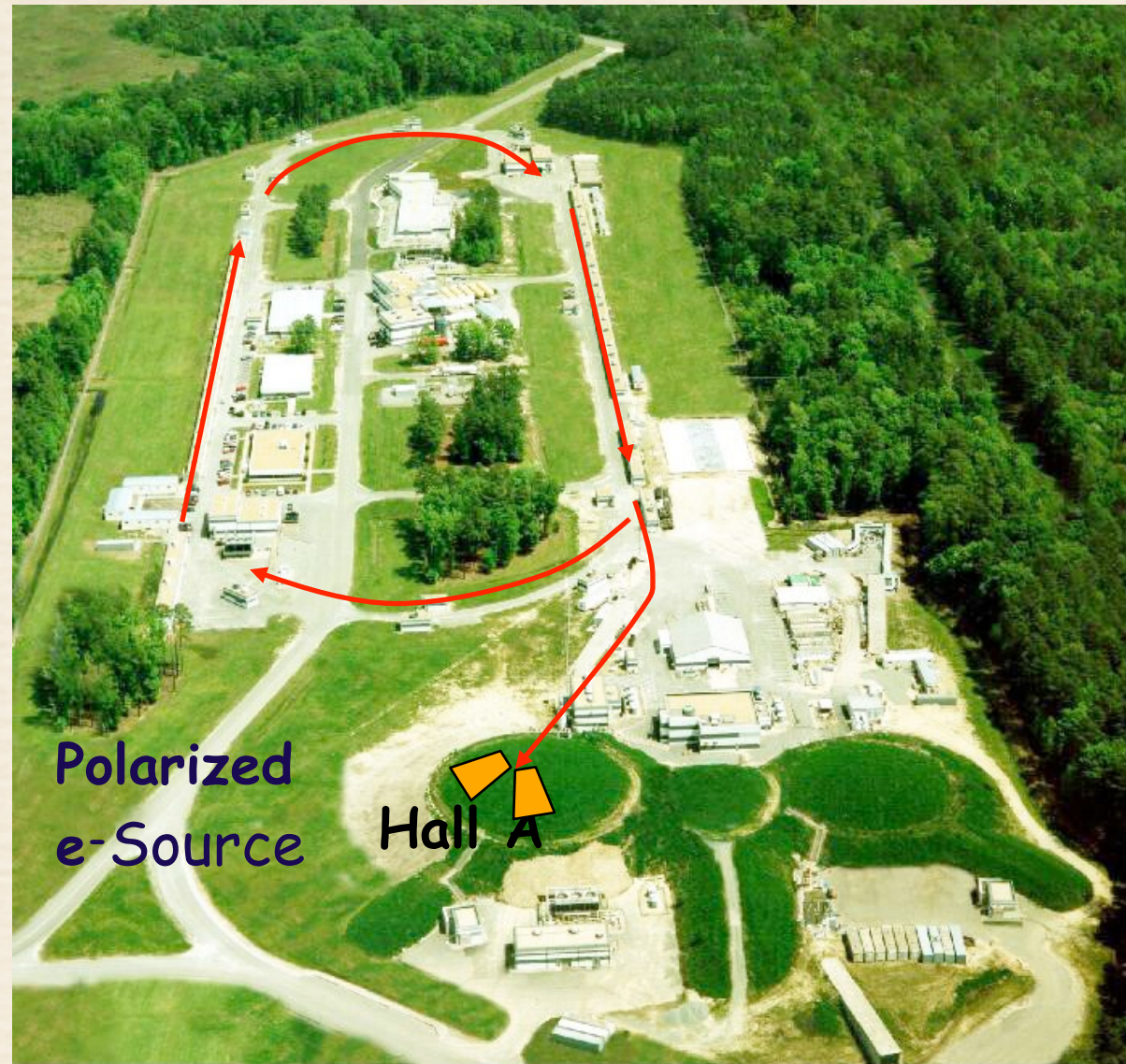

- ~ 50M\$ MIE by US DOE NP
- ~ 12M\$: US NSF and Canada CFI/Research Manitoba
- CD-1 granted in Dec 2020
- **CD-2/3 granted May 2024**
- **Construction: 2024-25**
- **Installation 2025-2026**
- **Commissioning: Early 2027**
- **Physics thru 2029 and beyond**

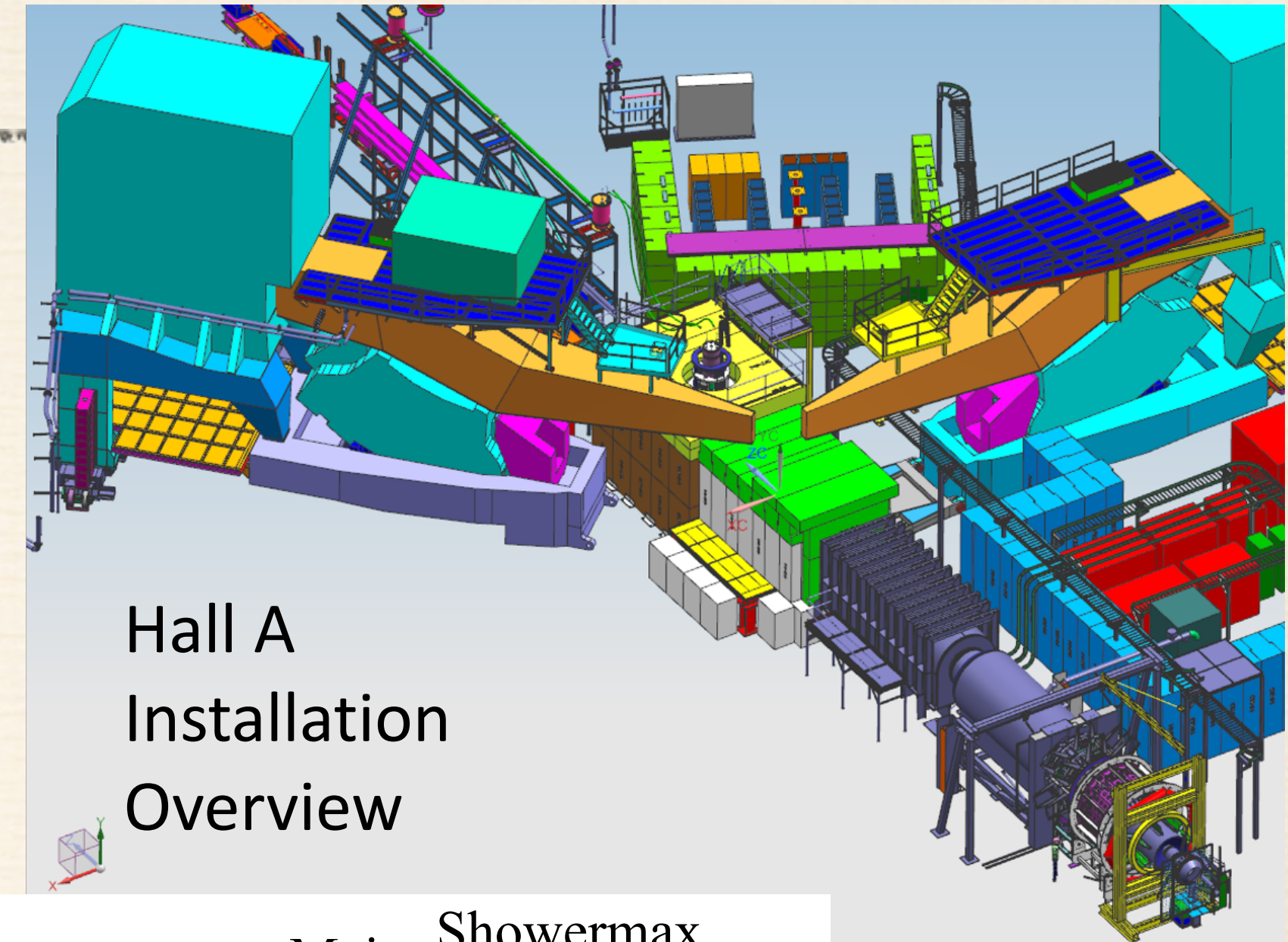

Hall A
Installation
Overview

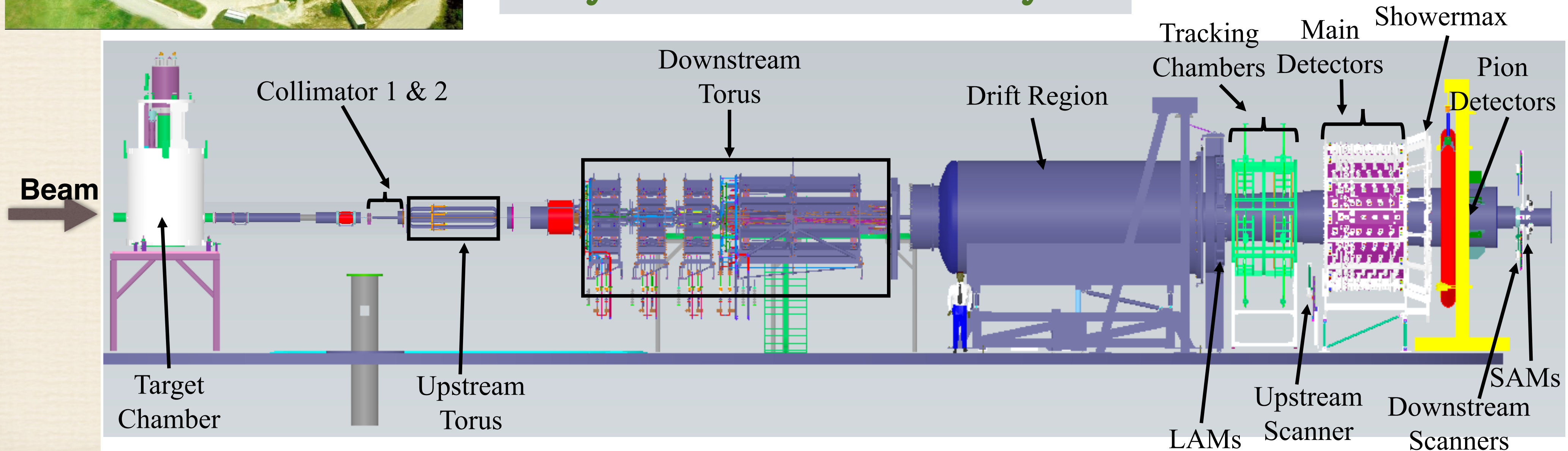

MOLLER Under Construction!

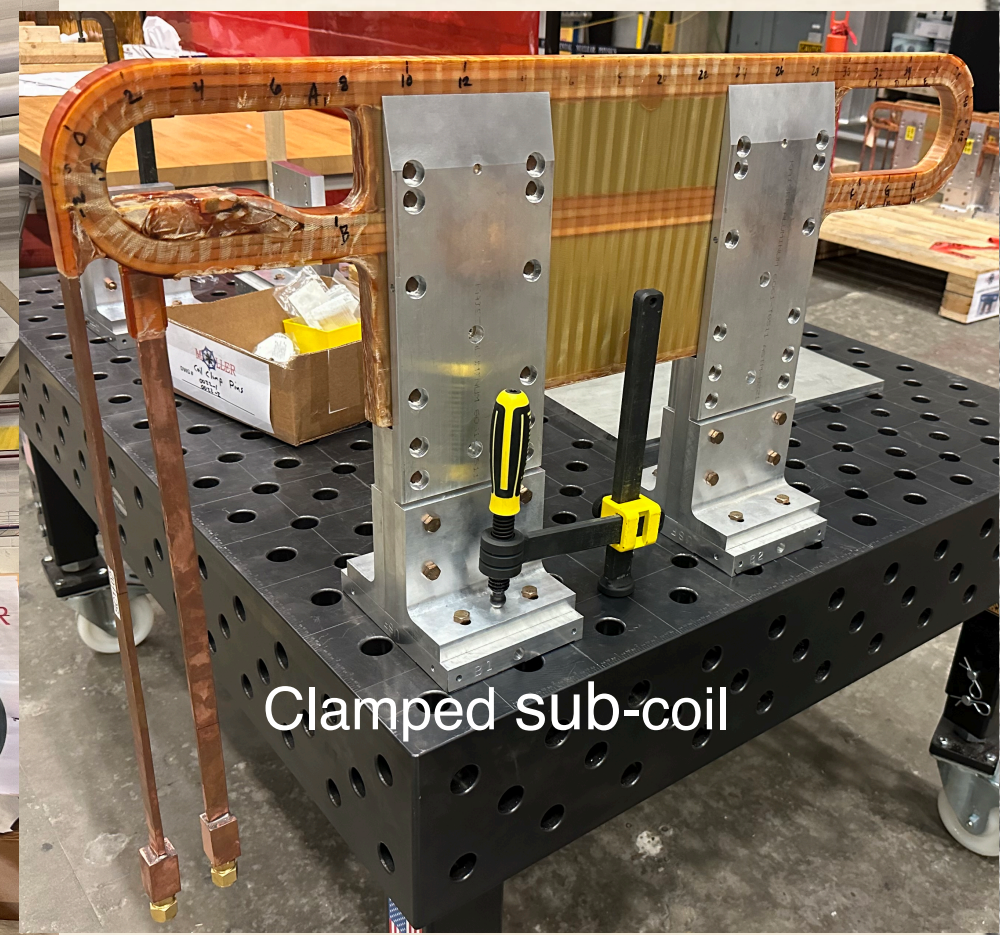
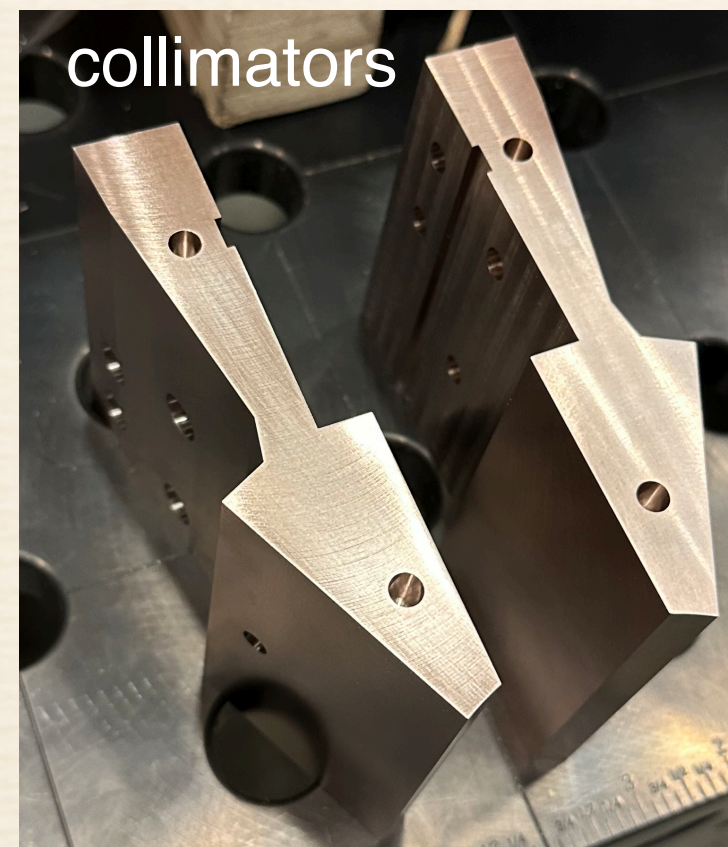
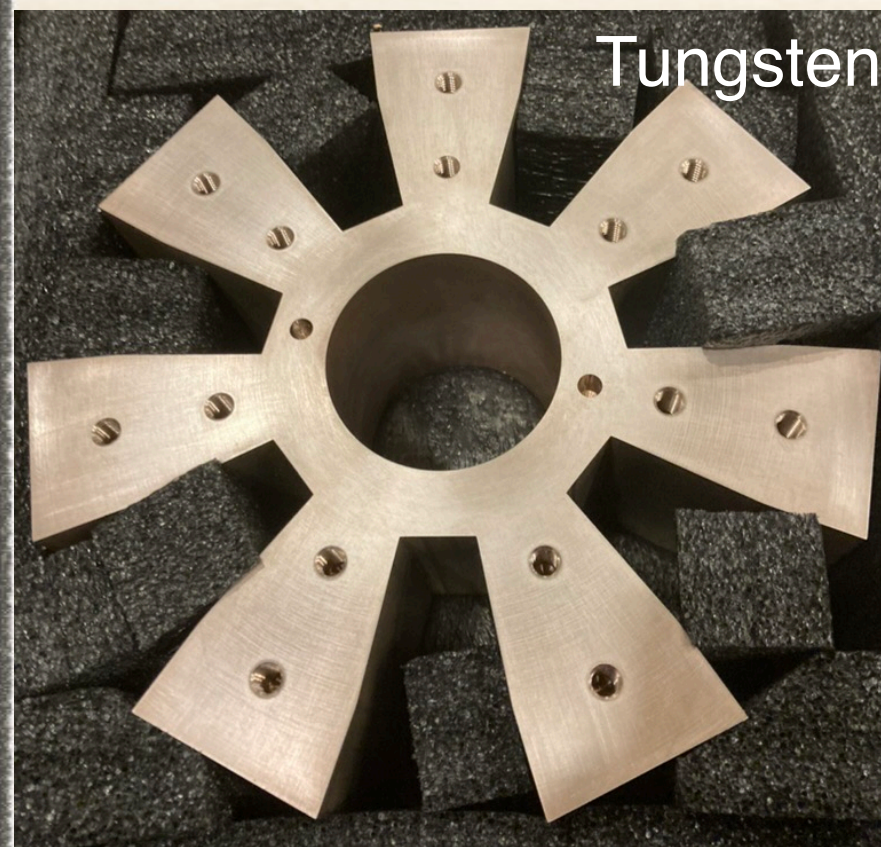
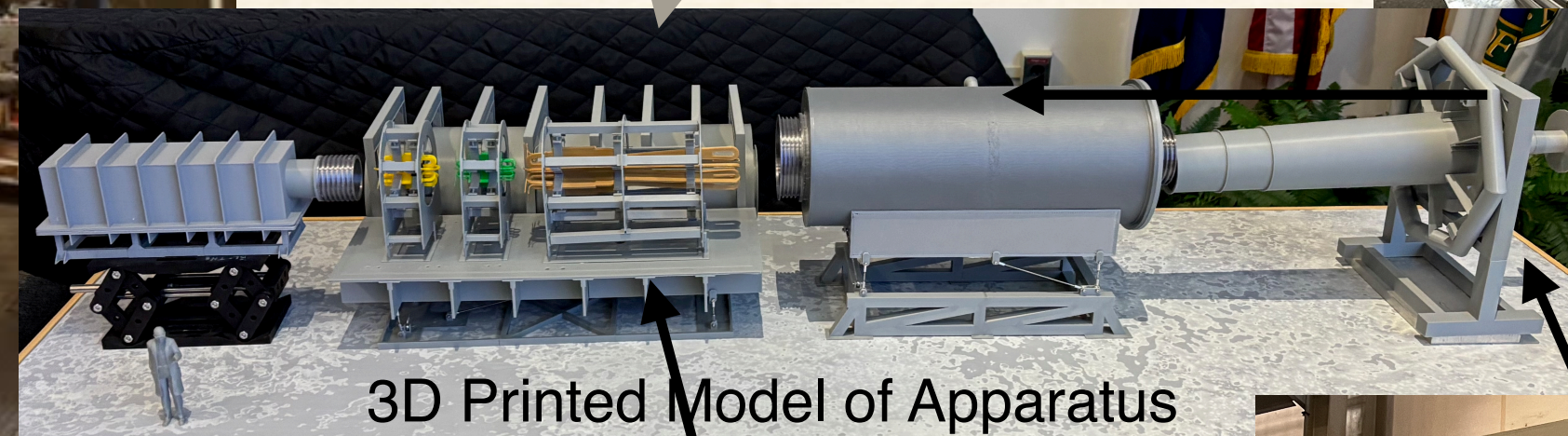

MOLLER: Key Numbers

- 2027: First physics running
- 2028: Publish number matching E158
- 2030: Accumulate statistics for ultimate precision

Uncertainty budget for A_{PV}

Error Source	Fractional Error (%)
Statistical	2.1
Absolute Norm. of the Kinematic Factor	0.5
Beam (second order)	0.4
Beam polarization	0.4
$e + p(+\gamma) \rightarrow e + X(+\gamma)$	0.4
Beam (position, angle, energy)	0.4
Beam (intensity)	0.3
$e + p(+\gamma) \rightarrow e + p(+\gamma)$	0.3
$\gamma^{(*)} + p \rightarrow (\pi, \mu, K) + X$	0.3
Transverse polarization	0.2
Neutral background (soft photons, neutrons)	0.1
Linearity	0.1
Total systematic	1.1

$$\delta(\sin^2\theta_W) = \pm 0.00023 \text{ (stat.)} \pm 0.00012 \text{ (syst.)}$$

$$\Lambda_{RR-LL}^{ee} \sim 38 \text{ TeV}$$

Møller A_{PV} Theory Uncertainty

$\sin^2 \theta_W$ Running: well under control $\sim 0.2\%$
Eler and Ferro-Hernandez (2018)

However, shift if using Lattice for HVP: $\sim 0.5\%$
Eler, Ferro-Hernandez & Kuberski (2024)

Current overall uncertainty with leading 2-loop: $\sim 0.4\%$
Du, Freitas, Patel, Ramsey-Musolf (2021)
Eler, Ferro-Hernandez & Freitas (2022)

Ongoing work: Looking forward to upcoming talks
NNLO EW Corrections: Lisong Chen
McMule Framework: Sophie Kollatzsch et al.

Outcome of this Workshop:

What efforts and collaborations are required to maximize MOLLER physics output?

MOLLER Auxilliary
Topics

MOLLER Spectrometer

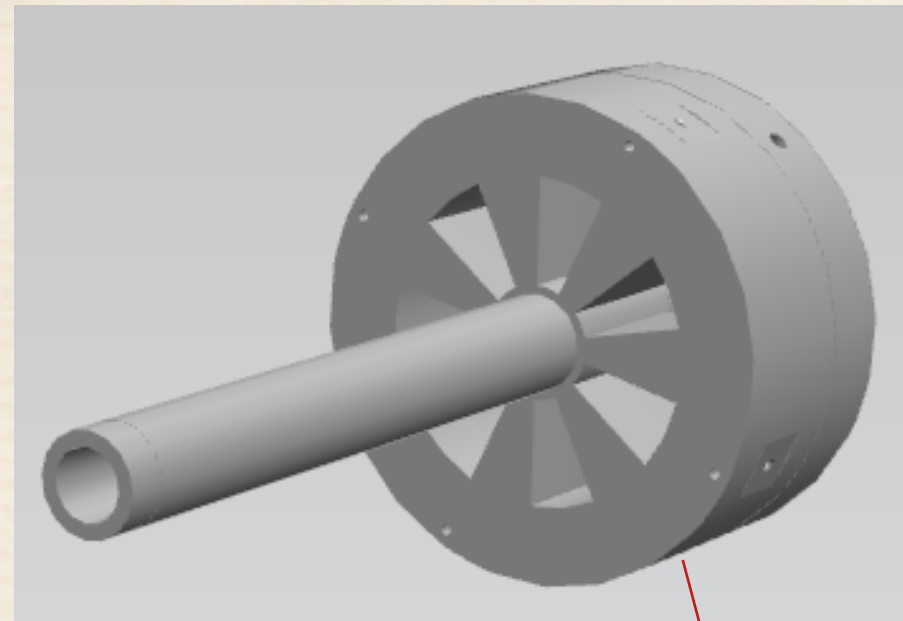

Acceptance defining collimator 1 & 2

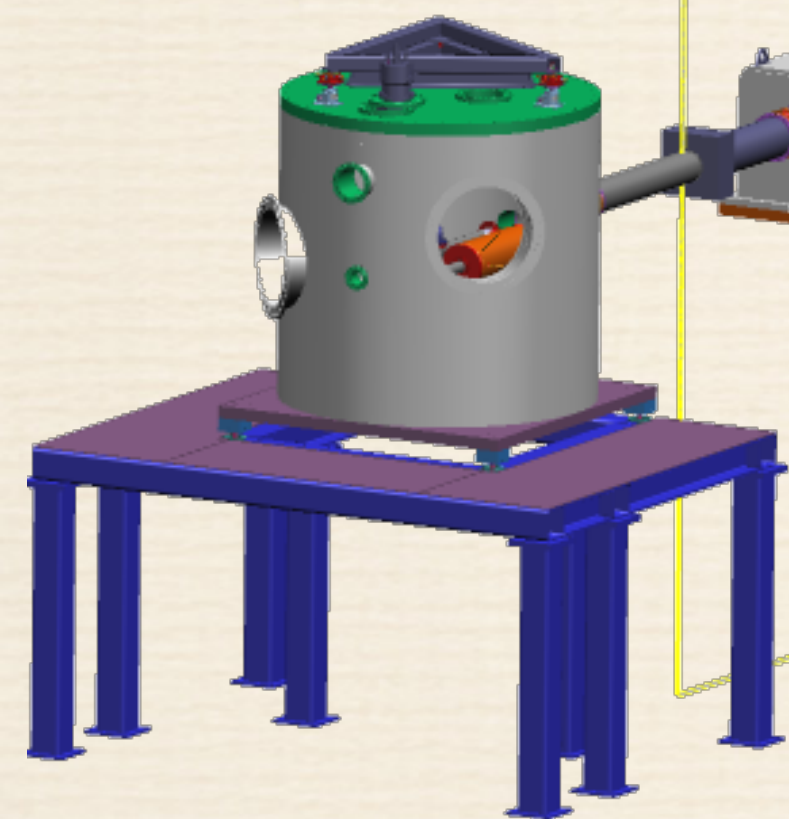

radial field component focuses the smaller angles and stretches the larger angles over the azimuth

flux distribution

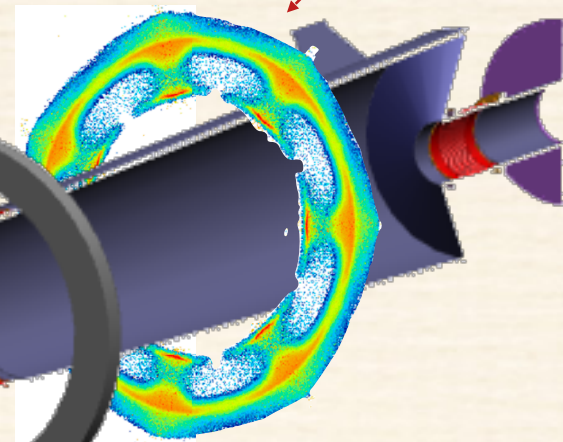

rate(GHz/uA/sep/5mm) vs r(mm)

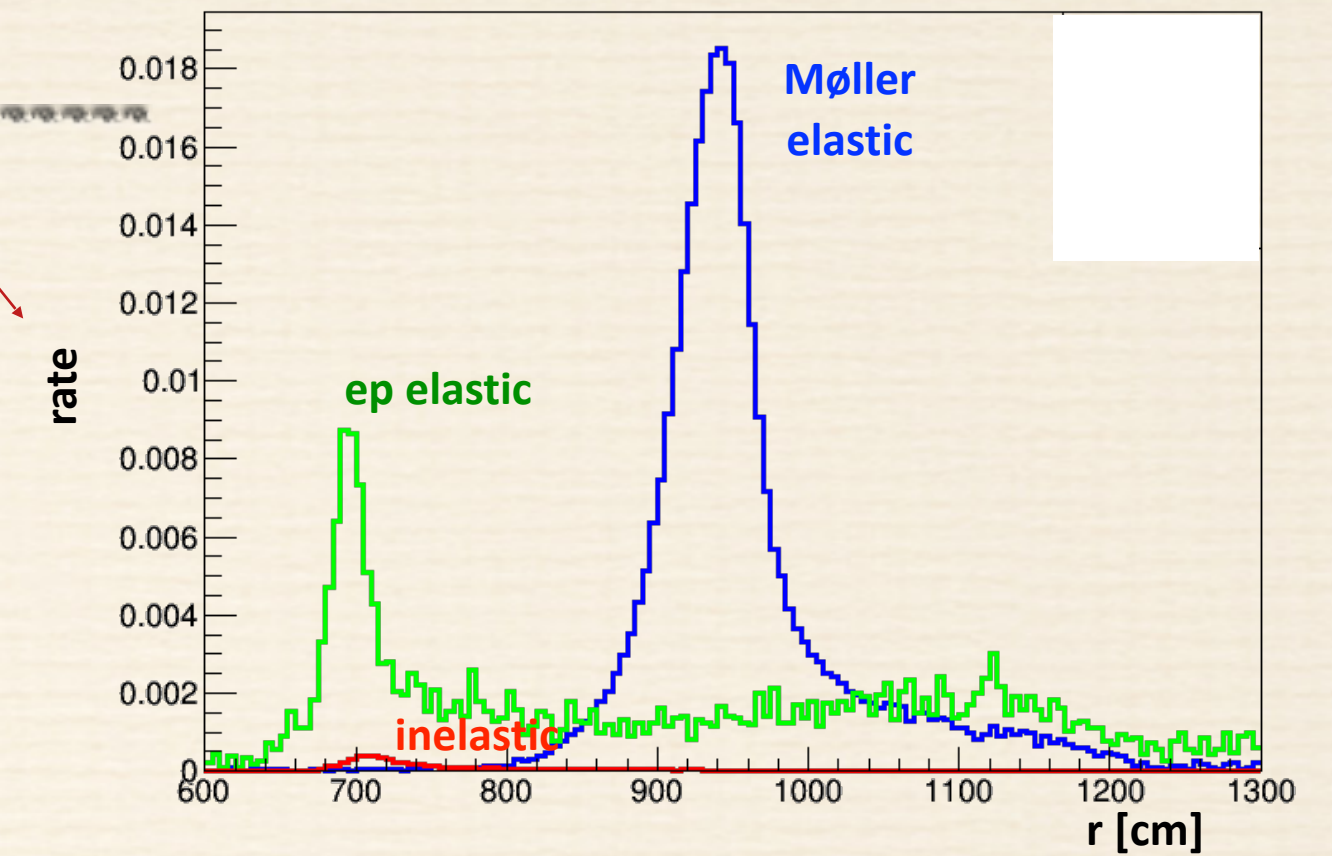

5 toroidal coils of varying strength and shape

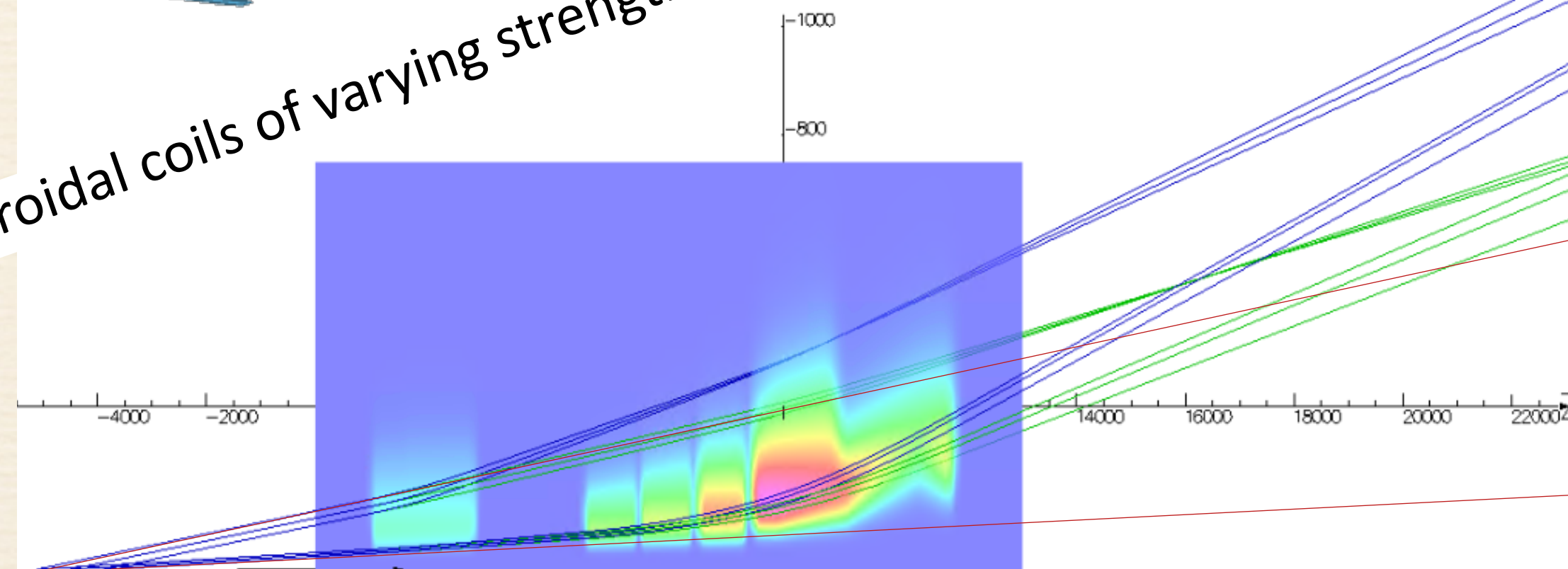

map E-θ correlation for ee scattering to detector

Møller scatters from $5 < \theta_{lab} < 20$ mrad

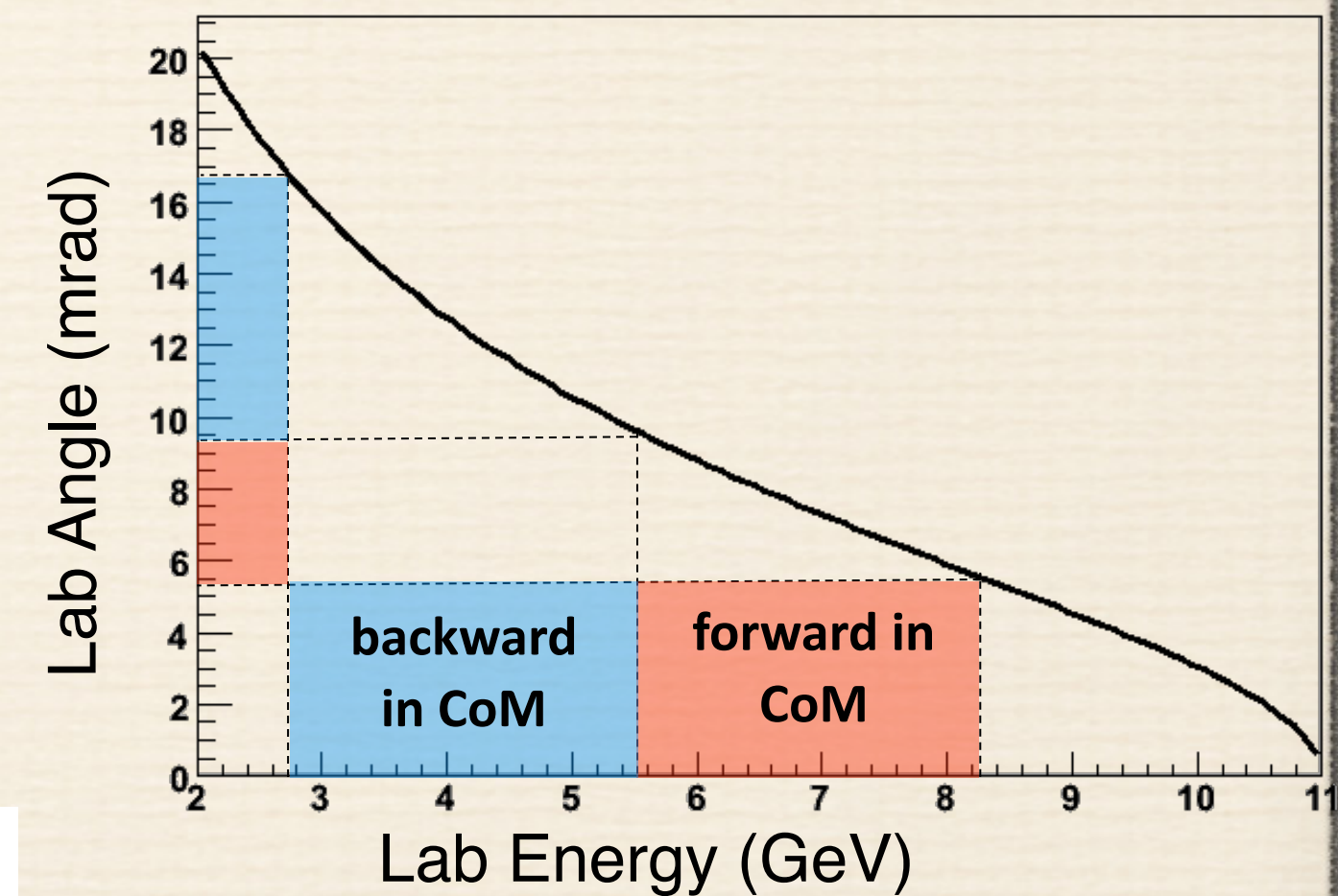

Capturing the Scattered Flux

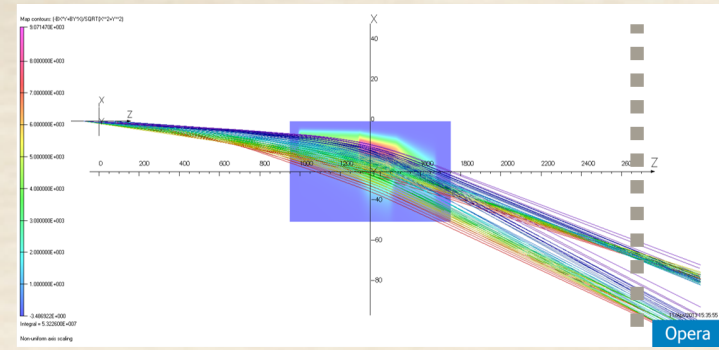

Heat map on transverse plane 26.5 m from target center

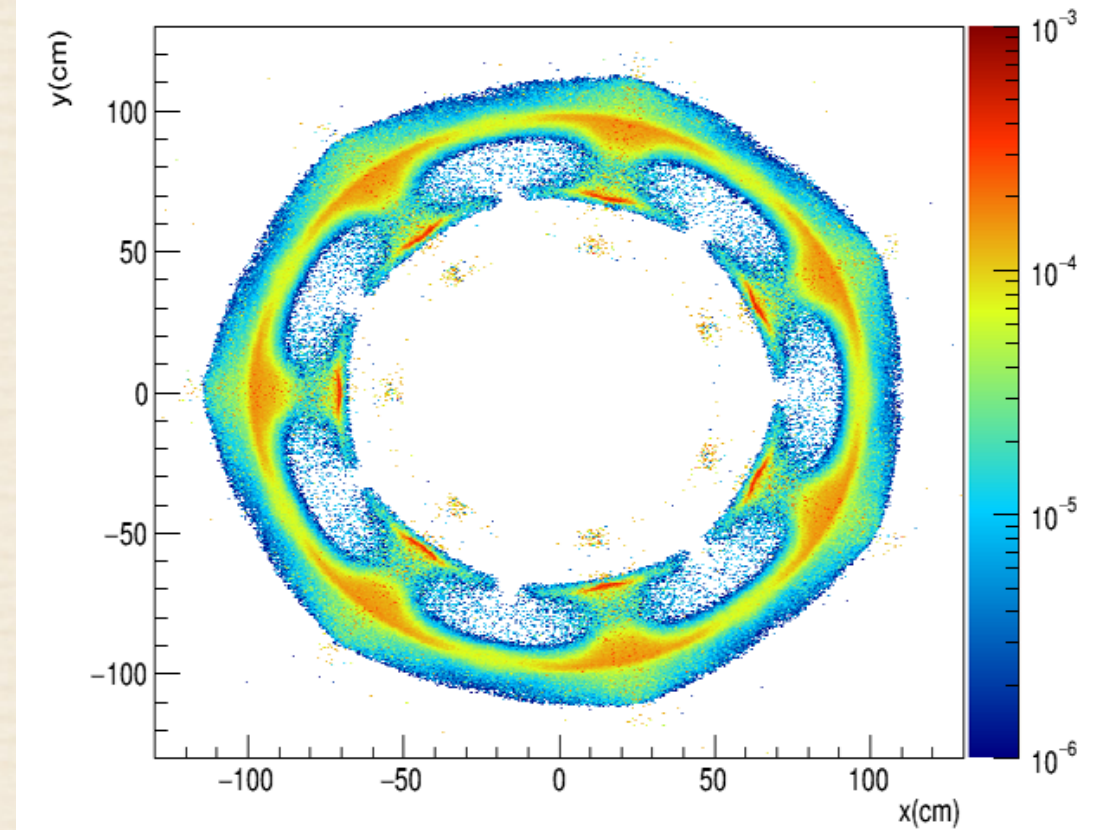

1/7 of the azimuth showing tiling segmentation

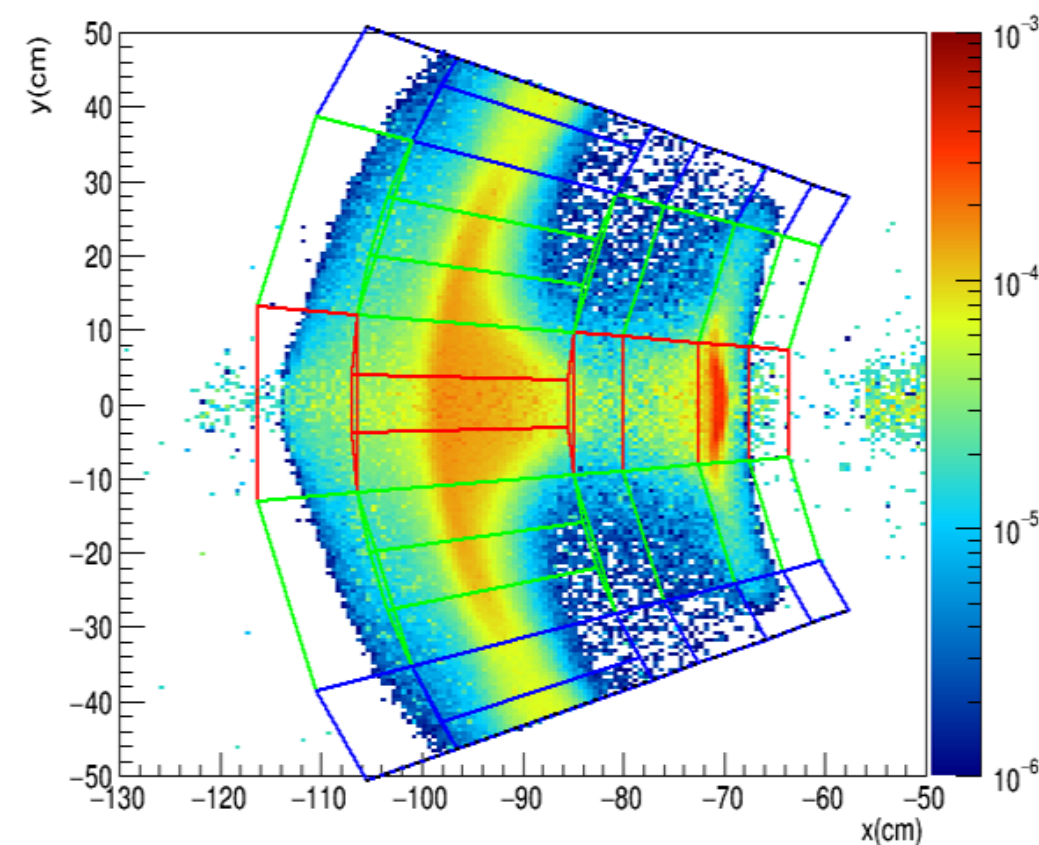

Wide variation in flux intensity and weights of different scattering processes: 1) *e-e*, 2) *elastic e-p*, 3) *inelastic e-p*

Both radial and azimuthal segmentation in scattered flux measurements required

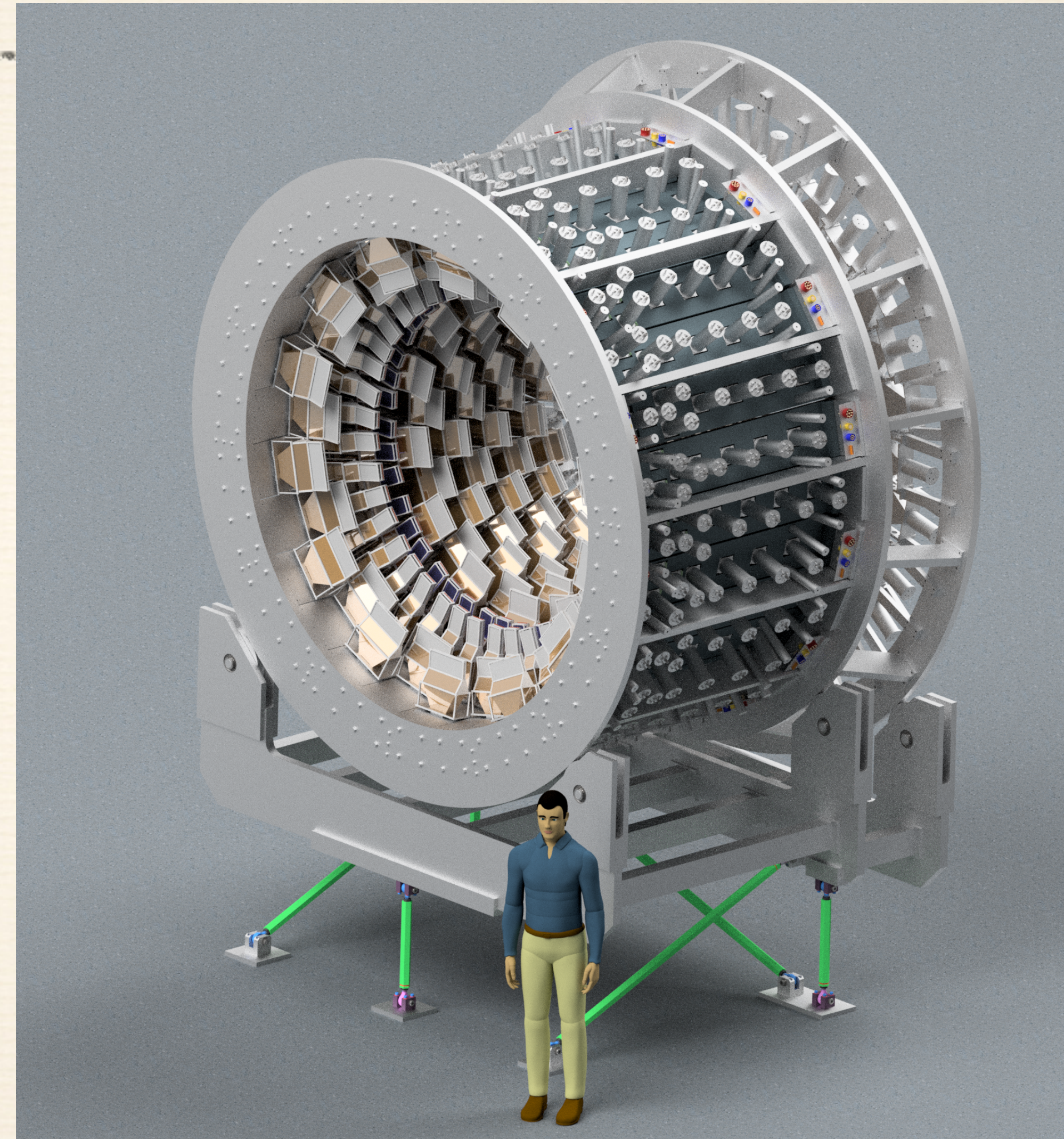
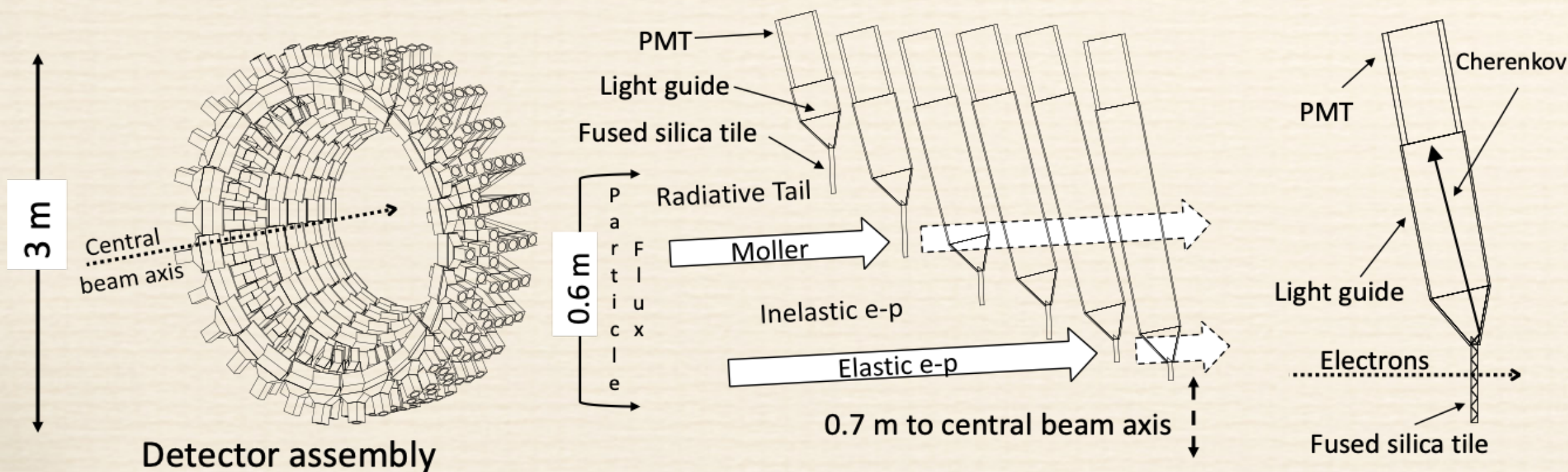

Sometimes called the Transverse Asymmetry A_T

Beam Normal Single Spin Asymmetry

B_n asymmetry

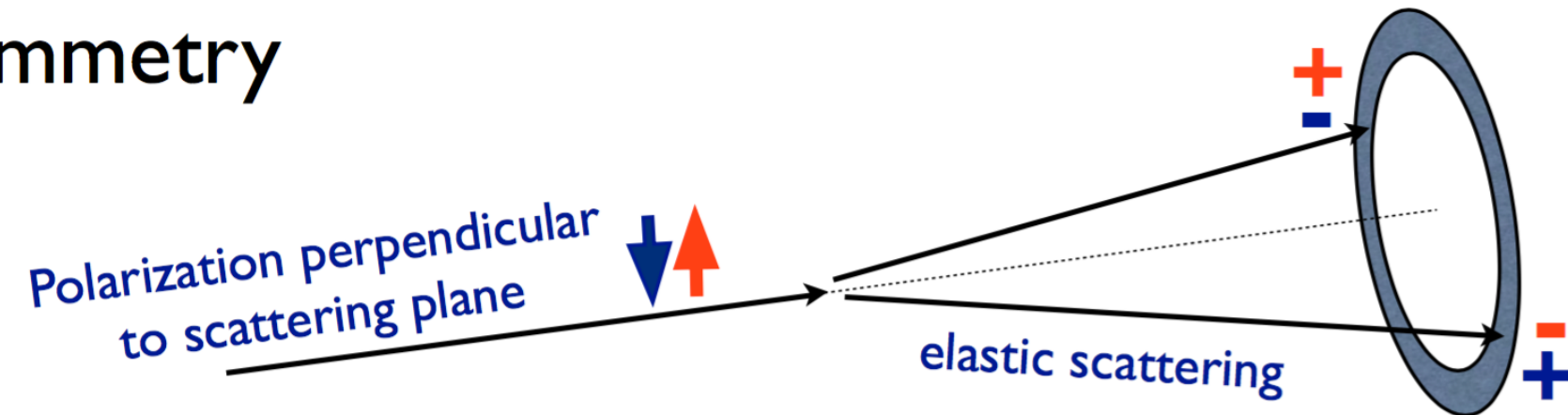

time-reversal invariance forces this SSA to vanish for one-photon exchange
arises from an interference between the one-photon exchange (Born) amplitude and the imaginary part of the two-photon exchange amplitude

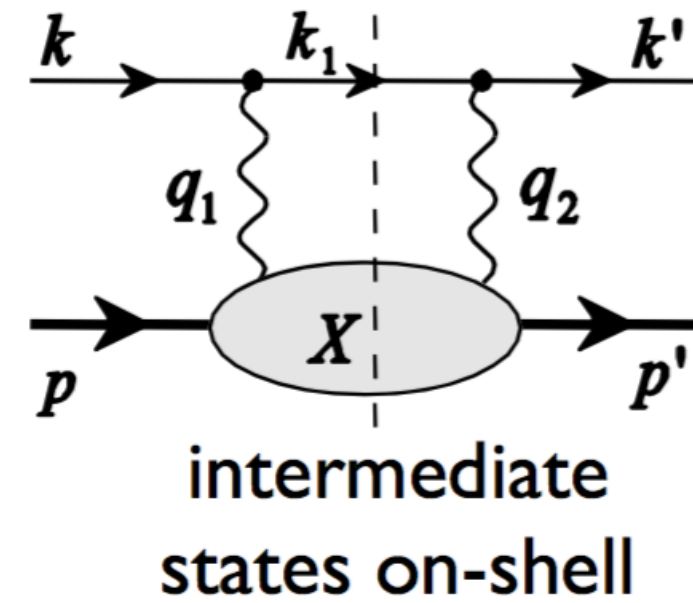

$$B_n = \frac{\sigma_{\uparrow} - \sigma_{\downarrow}}{\sigma_{\uparrow} + \sigma_{\downarrow}} = \frac{2\text{Im}(T_{2\gamma} \cdot T_{1\gamma}^*)}{|T_{1\gamma}|}$$

Asymmetry is very small $B_n \sim \alpha_{em} \frac{m_e}{E_e} \sim 10^{-6} - 10^{-5}$
2-photon \nearrow ultra-relativistic

B_n must vanish at 90 degrees in the COM for Møller scattering

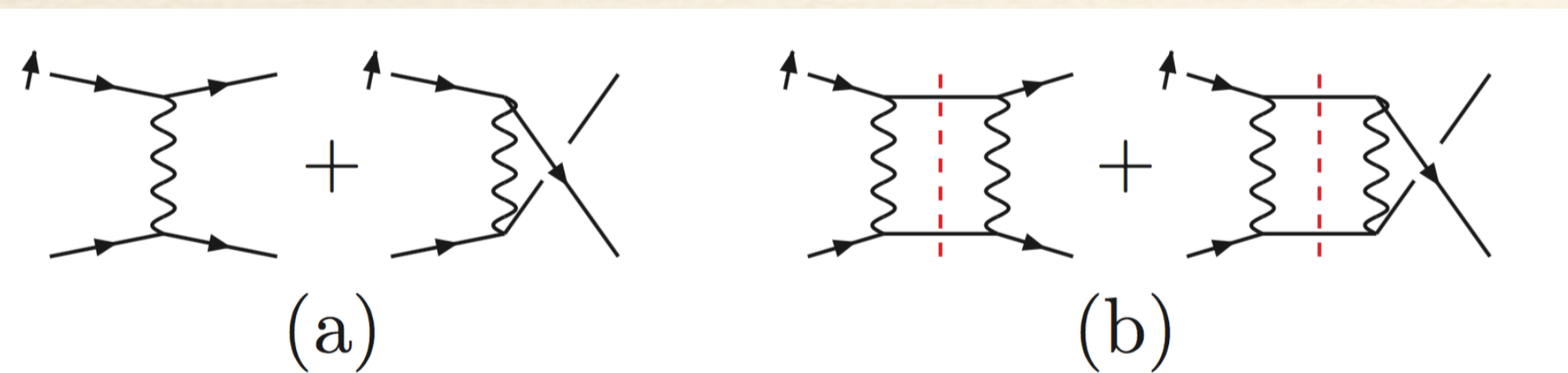

Møller Scattering: Dixon and Schreiber (2004)

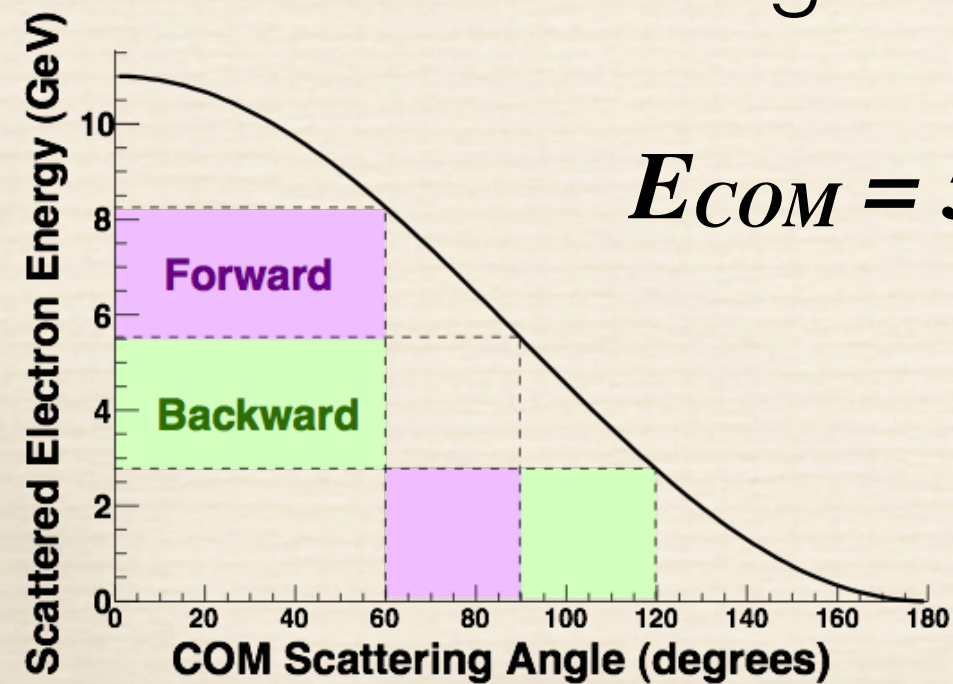
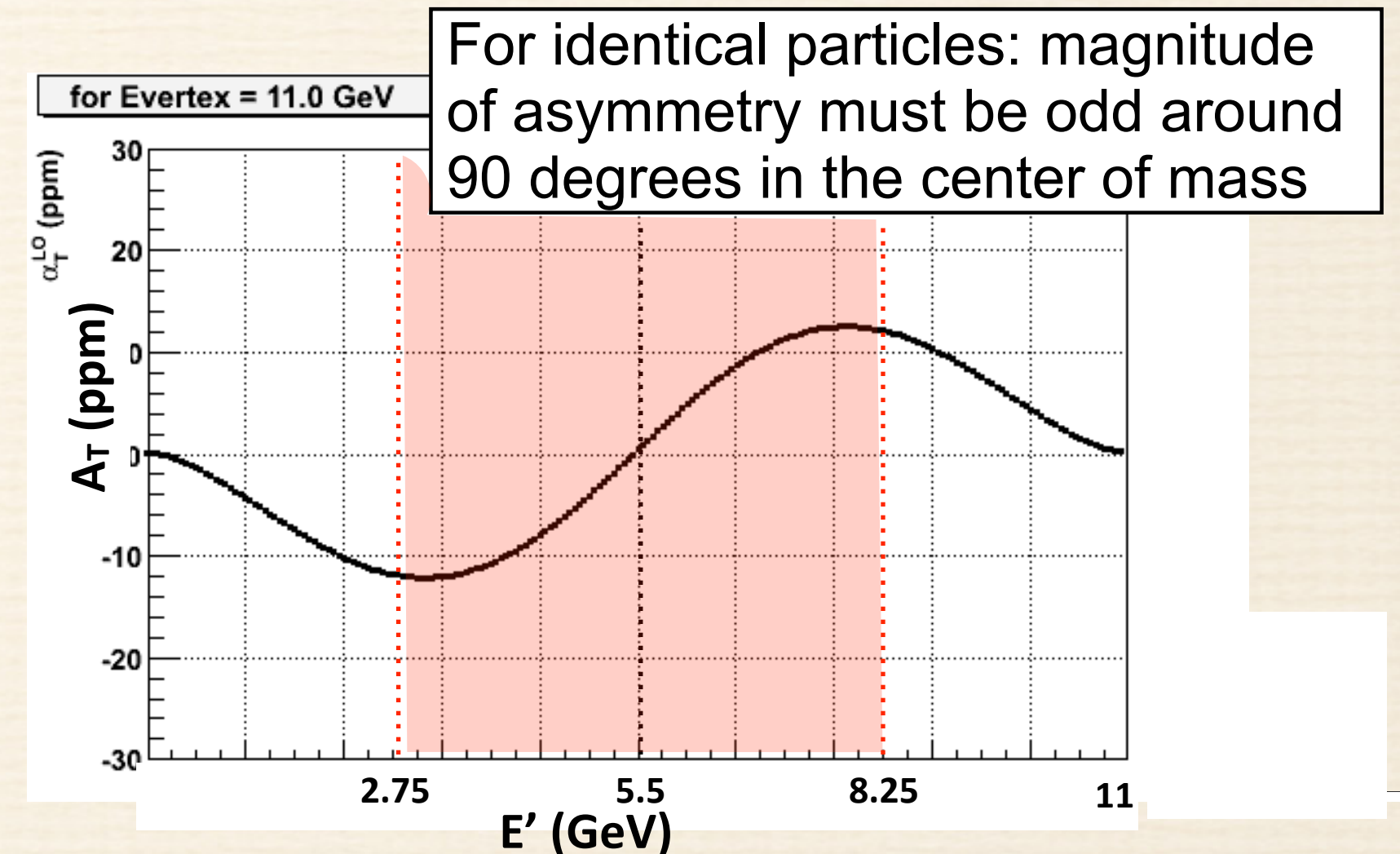
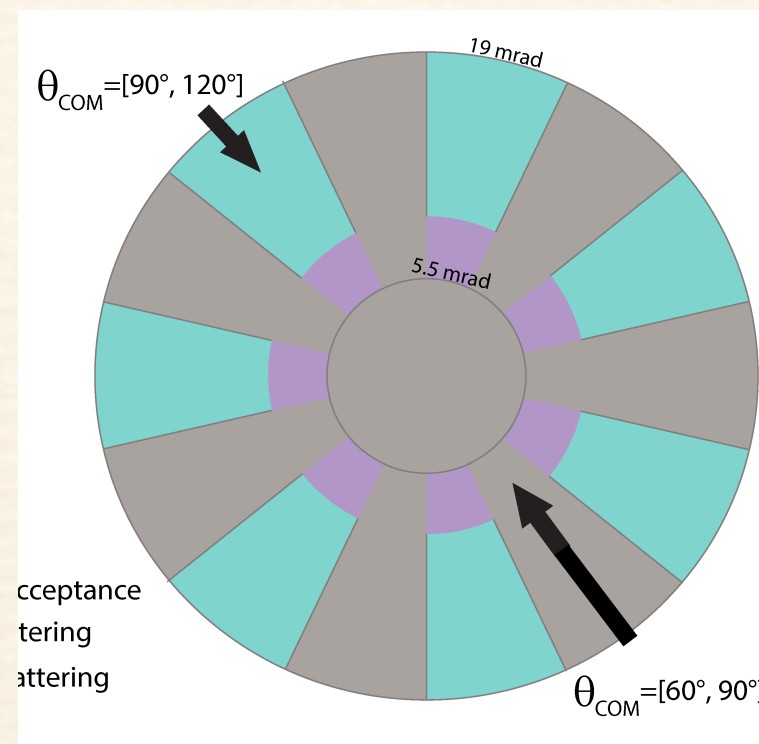

$E_{COM} = 53 \text{ MeV}$

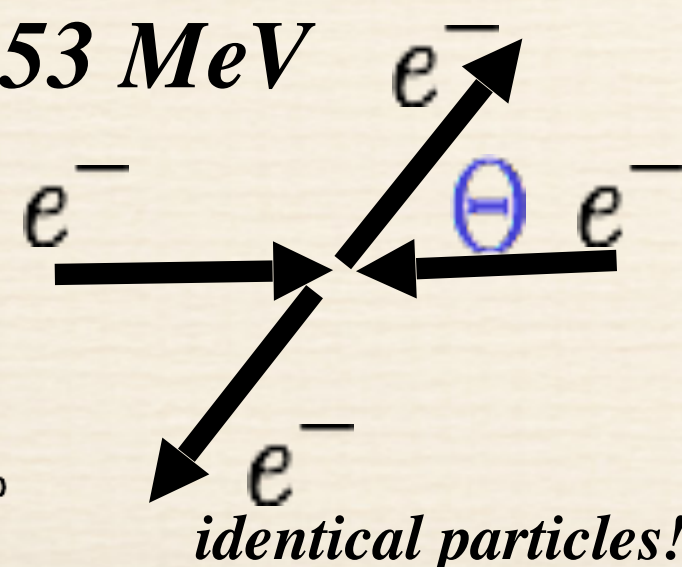

Because the B-field lines have a heptagon shape rather than a circle, charged particles undergo "azimuthal defocusing" i.e. azimuthal distribution becomes momentum-dependent!

MOLLER Early Run Strategy

Use the Beam Normal Asymmetry to Calibrate the Apparatus

- set up for physics running
- convert to vertical polarization
- run a few hours to few days
- extract B_n precision & accuracy much better than 0.5%

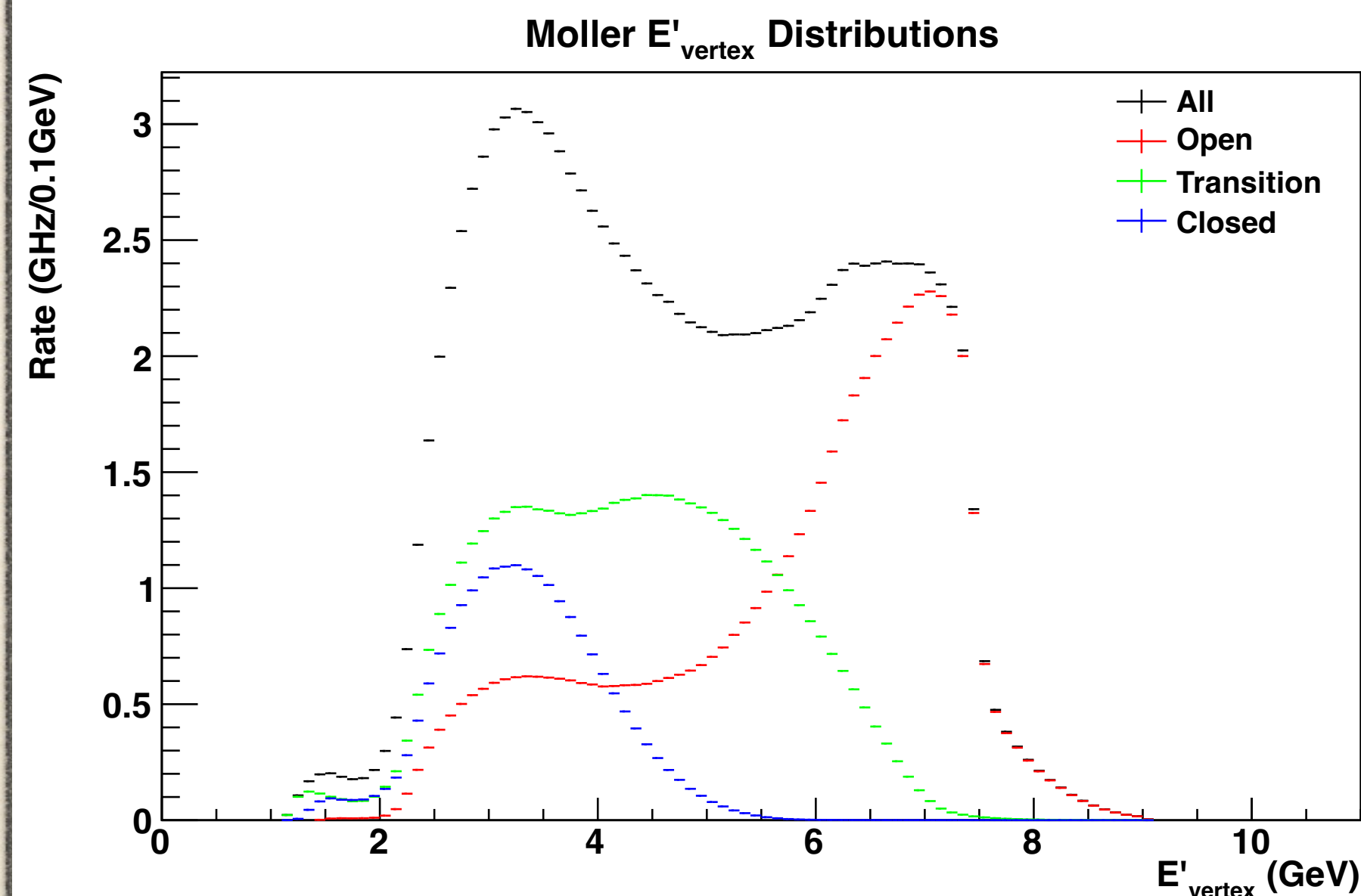
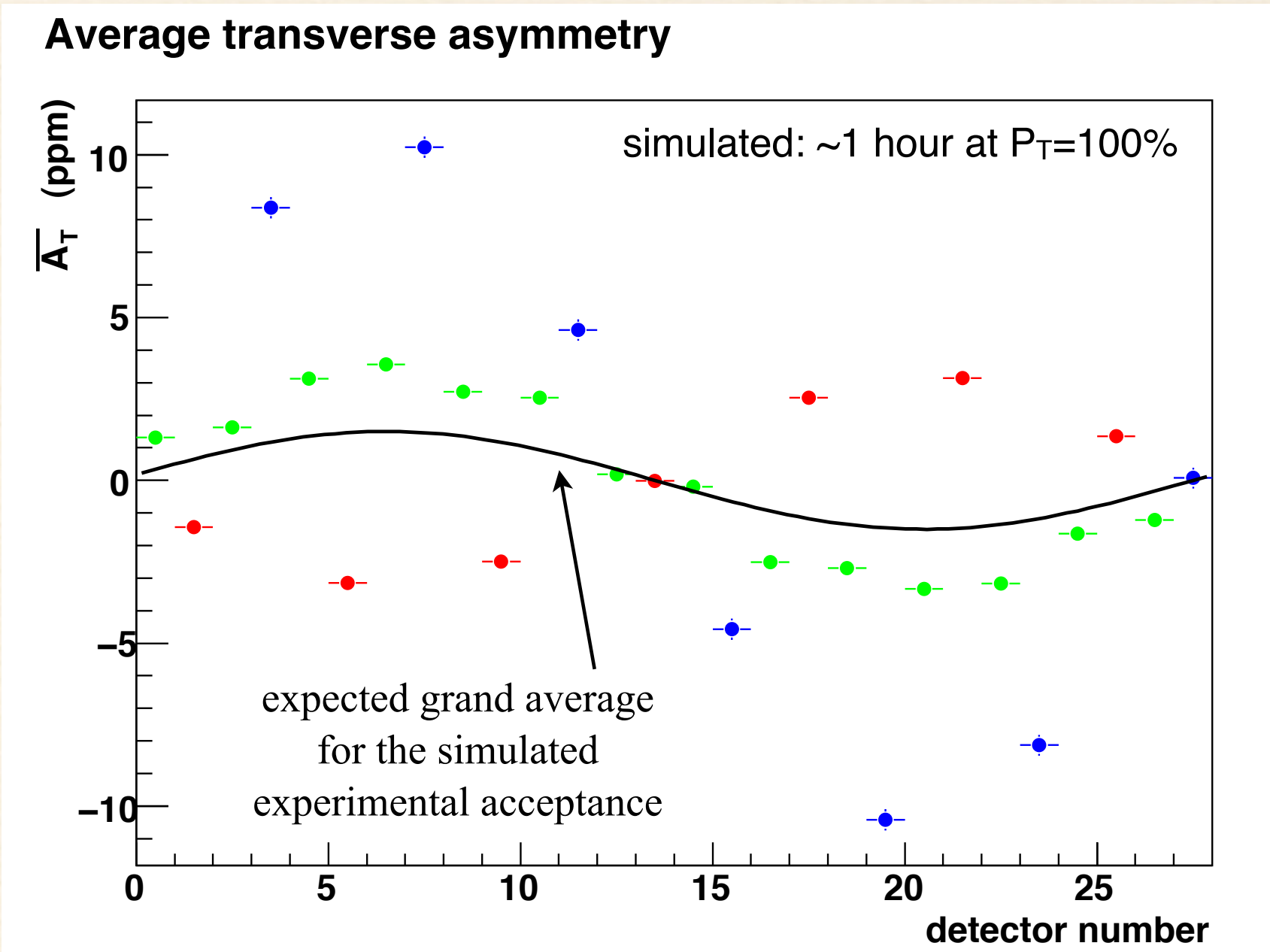
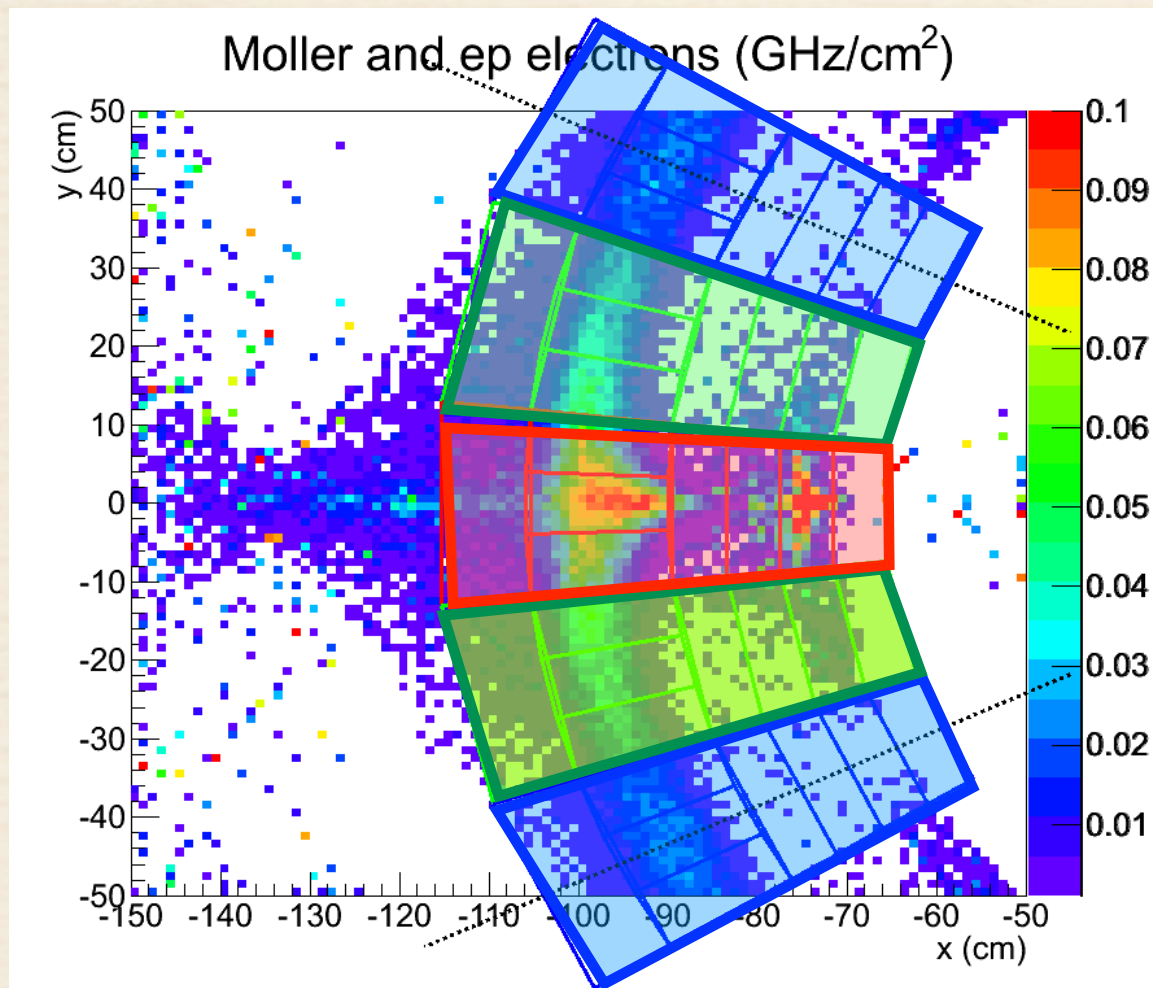

*demonstrate complete understanding of apparatus: **simultaneous test of beam polarization, radiative corrections, detector acceptance, backgrounds***

Is Møller B_n theory good to 0.1% with Dixon/Schreiber work?

Also worth noting that we will measure B_n simultaneously for elastic and inelastic e-p scattering

Extracting MOLLER Physics

Inclusive 11 GeV electron scattering off hydrogen

- ◆ Black: e-e scattering
- ◆ Red: elastic e-p scattering
- ◆ Green: inelastic e-p scattering
- ◆ Dark blue: elastic e-Al scattering
- ◆ Light blue: inelastic e-Al scattering
- ◆ Magenta: Al quasi-elastic scattering

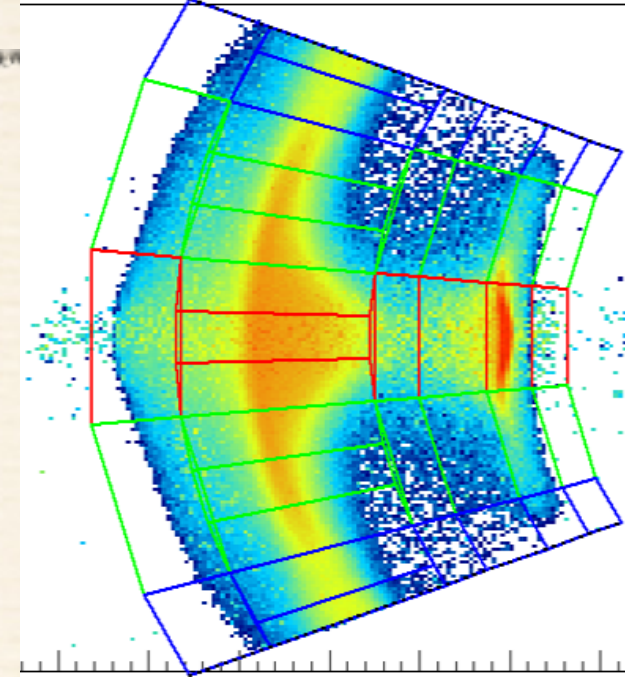

- 16 different tile asymmetries
- “Pre-subtract” Al and pion asymmetry contributions
- Simultaneous fit to 16 measurements with different contributions of e-e, e-p elastic, ep-inelastic
- Extract the “weak charge” for e-e, e-p elastic and inelastic e-p for 3 different W ranges

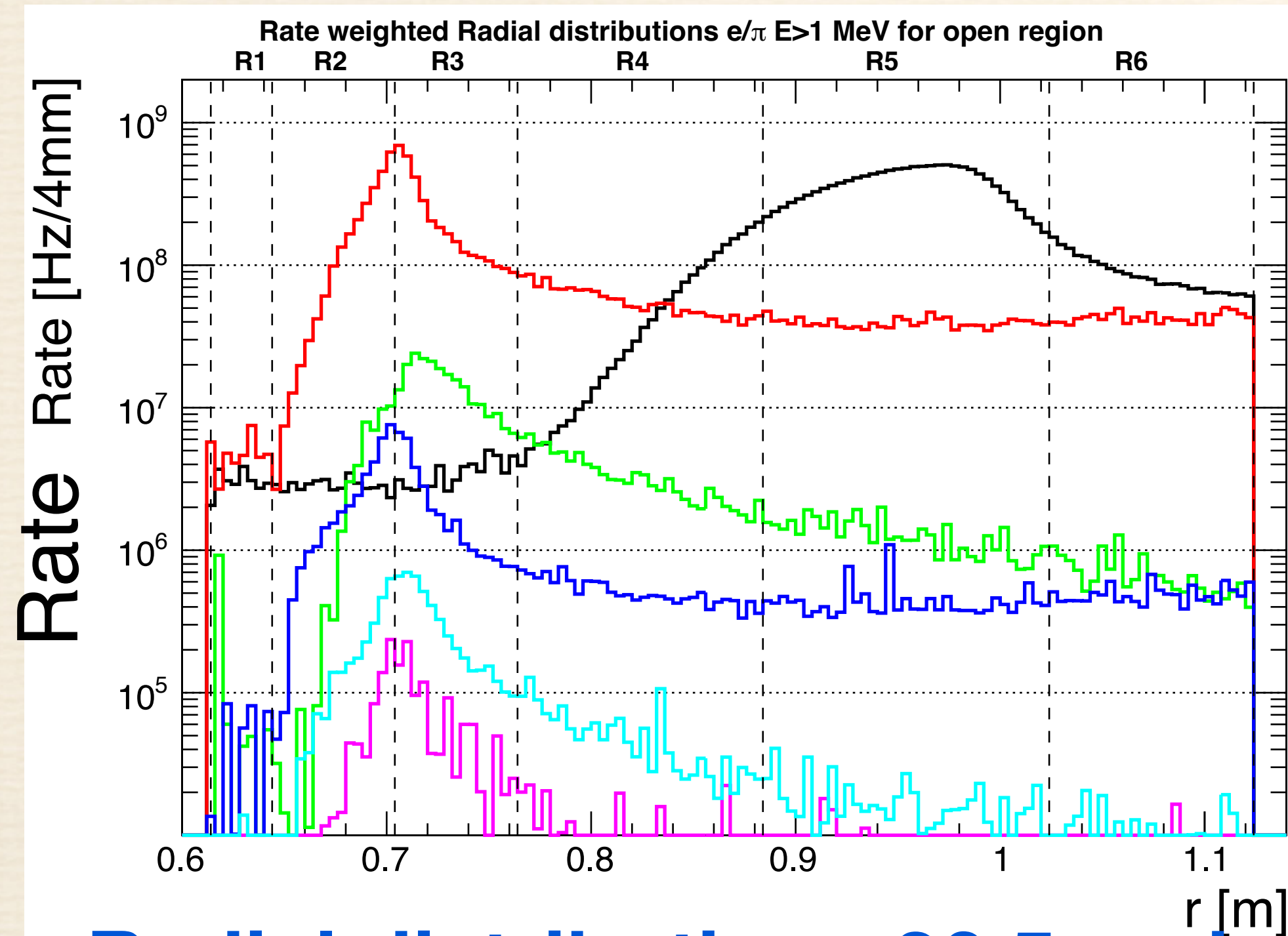

Rate-weighted

Asymmetry

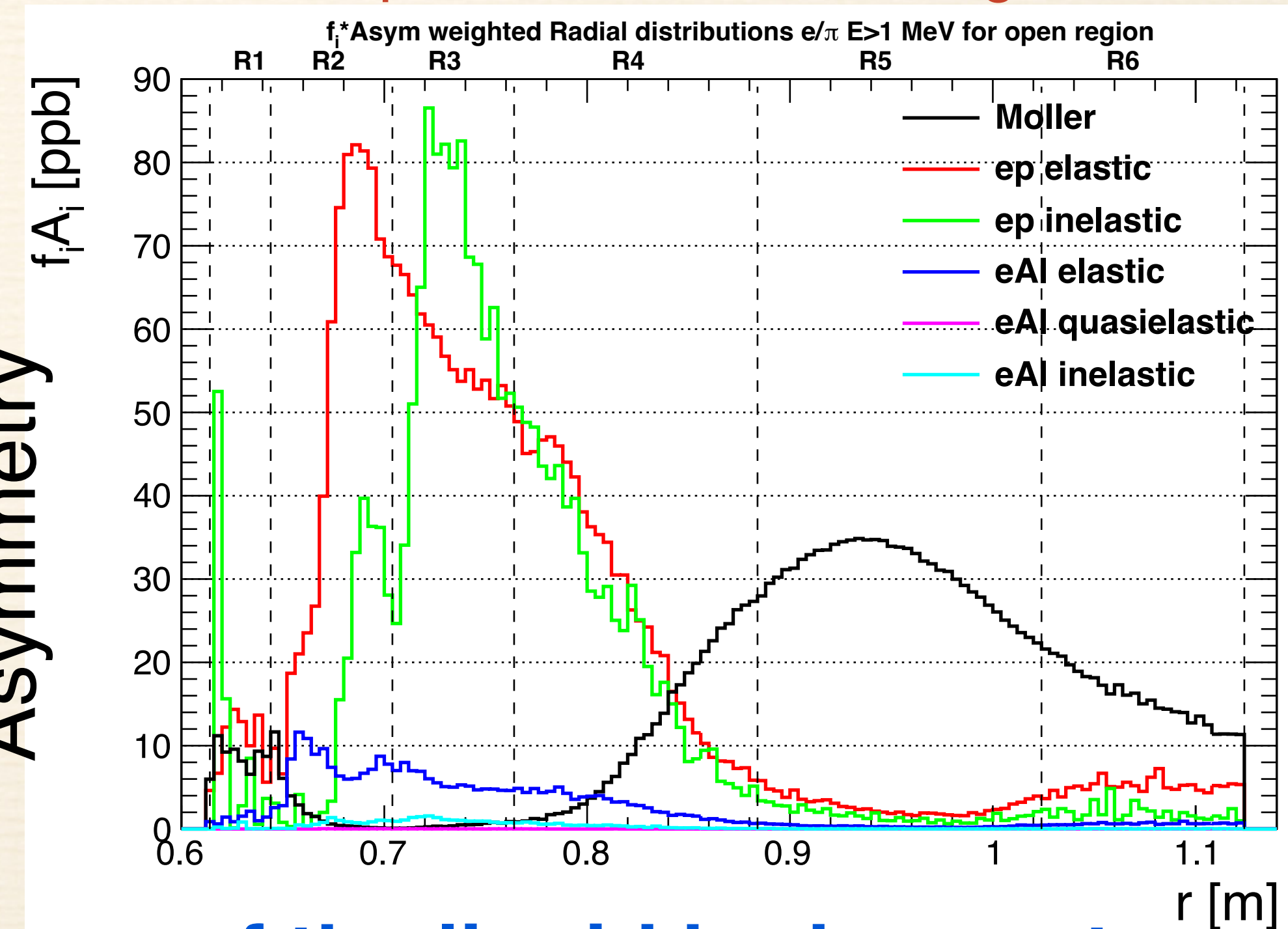

Radial distributions 26.5 m downstream of the liquid hydrogen target

PV Electron-Proton Inelastic Scattering

Assumption: $A_{PV}/Q^2 \sim F(W)$ is constant in 3 W regions

Mock Fit Extraction with Monte Carlo Trial Data Fit

Processes	Expected A (ppb)	σ_A (ppb)	$\frac{\sigma_A}{ A }$ (%)
Moller	-35.20	0.64	1.8
ep-elastic	-19.67	1.82	9.2
ep-inelastic (1)	-439.94	80.6	18.3
ep-inelastic (2)	-433.96	38.3	8.8
ep-inelastic (3)	-384.59	91.5	23.8
eAl-elastic	297.27	83.01	27.9

Corrections for Ring-5 Tiles after Fit Extraction

Process	Correction (%)	Systematic Error (%)
e-p elastic	1.14	0.08
e-p inelastic ($W < 1.4$ GeV)	-1.34	0.22
e-p inelastic ($1.4 < W < 2.5$ GeV)	-1.54	0.11
e-p inelastic ($W > 2.5$ GeV)	-1.66	0.35
e-Al elastic	0.87	0.09
e-Al other	< 0.10	< 0.10

Deep inelastic scattering

$$A_{PV} = \frac{G_F Q^2}{\sqrt{2}\pi\alpha} [a(x) + f(y)b(x)]$$

first principles: using electroweak neutral current structure functions

$$A_{PV} = \frac{G_F Q^2}{2\sqrt{2}\pi\alpha} \left[g_A \frac{F_1^{\gamma Z}}{F_1^\gamma} + g_V \frac{f(y)}{2} \frac{F_3^{\gamma Z}}{F_1^\gamma} \right]$$

At high Q^2 , one can use quark pdf's and standard model couplings. At forward angles, the prediction is $A_{PV}/Q^2 \sim 8.5 \times 10^{-5}$. However, for very low Q^2 , one needs a model as a function of W.

MOLLER kinematics:	$E_{\text{beam}} = 11$ GeV, $6 < \theta_{\text{lab}} < 20$ mrad, $E' = 3$ to 8 GeV	Diffractive Regime (VMD or Pomeron Physics)
	$Q^2 \sim 0.001 - 0.02$ GeV², W^2 from 1 to 20 GeV²	

Proton Weak Charge Box Diagram

Radiative corrections to the theoretical prediction of the weak charge of the proton

$$Q_W^p = (1 + \Delta\rho + \Delta_e) \left(1 - 4 \sin^2 \theta_W(0) + \Delta'_e \right) + \square_{WW} + \square_{ZZ} + \square_{\gamma Z}(0)$$

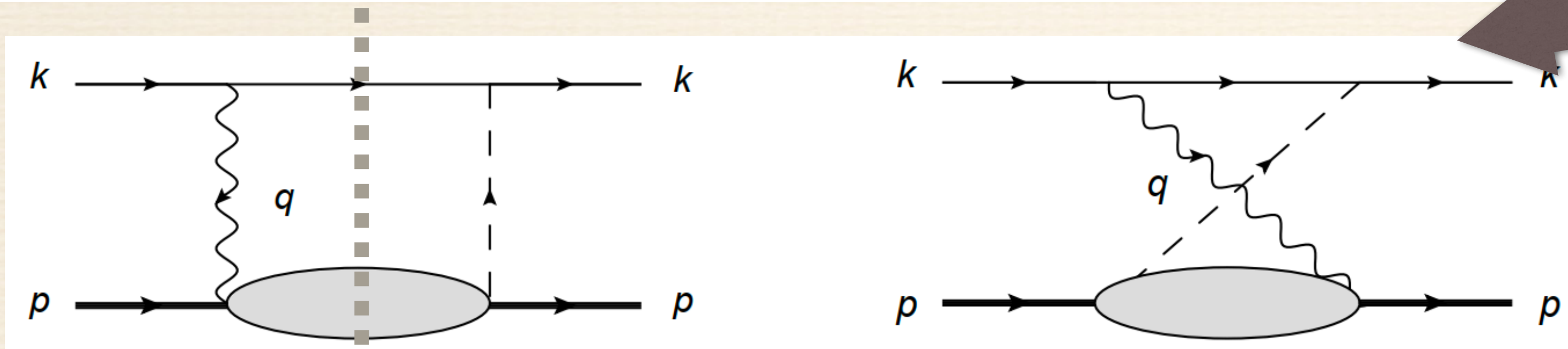

$$F_{1,2}^{\gamma Z}(Q^2, W^2)$$

In 3 different kinematic regimes

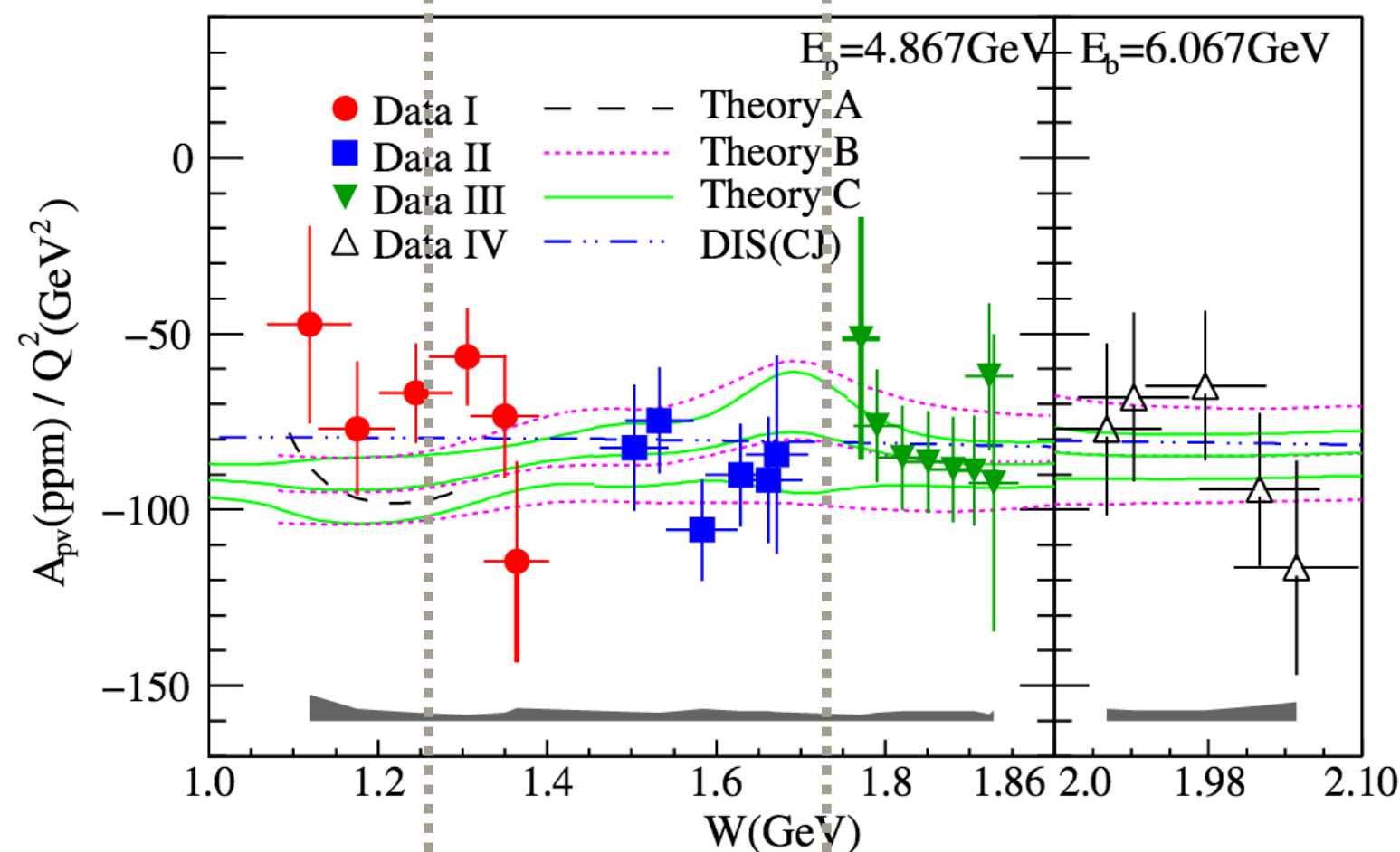
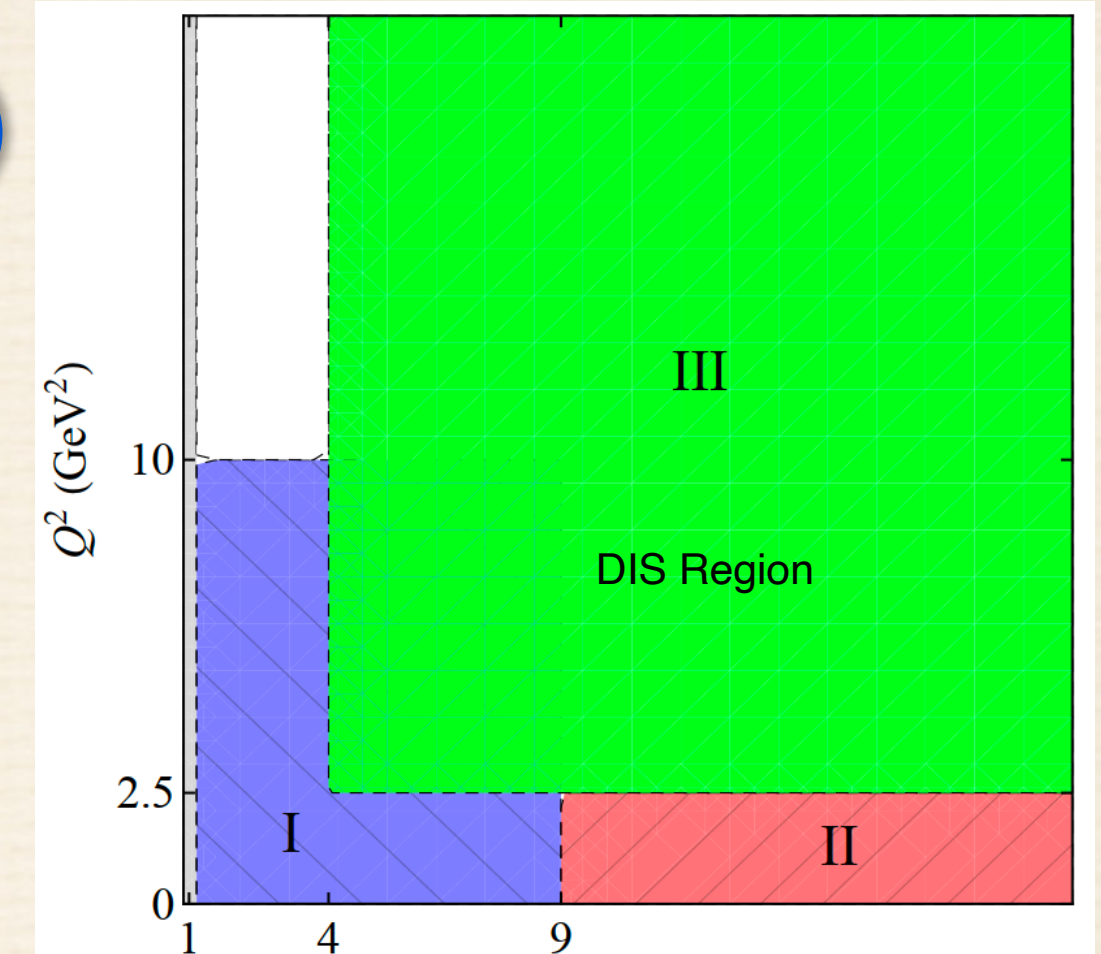

Matsui et al, Gorshtein et al, AJM, CJ, compared to PVDIS measurements

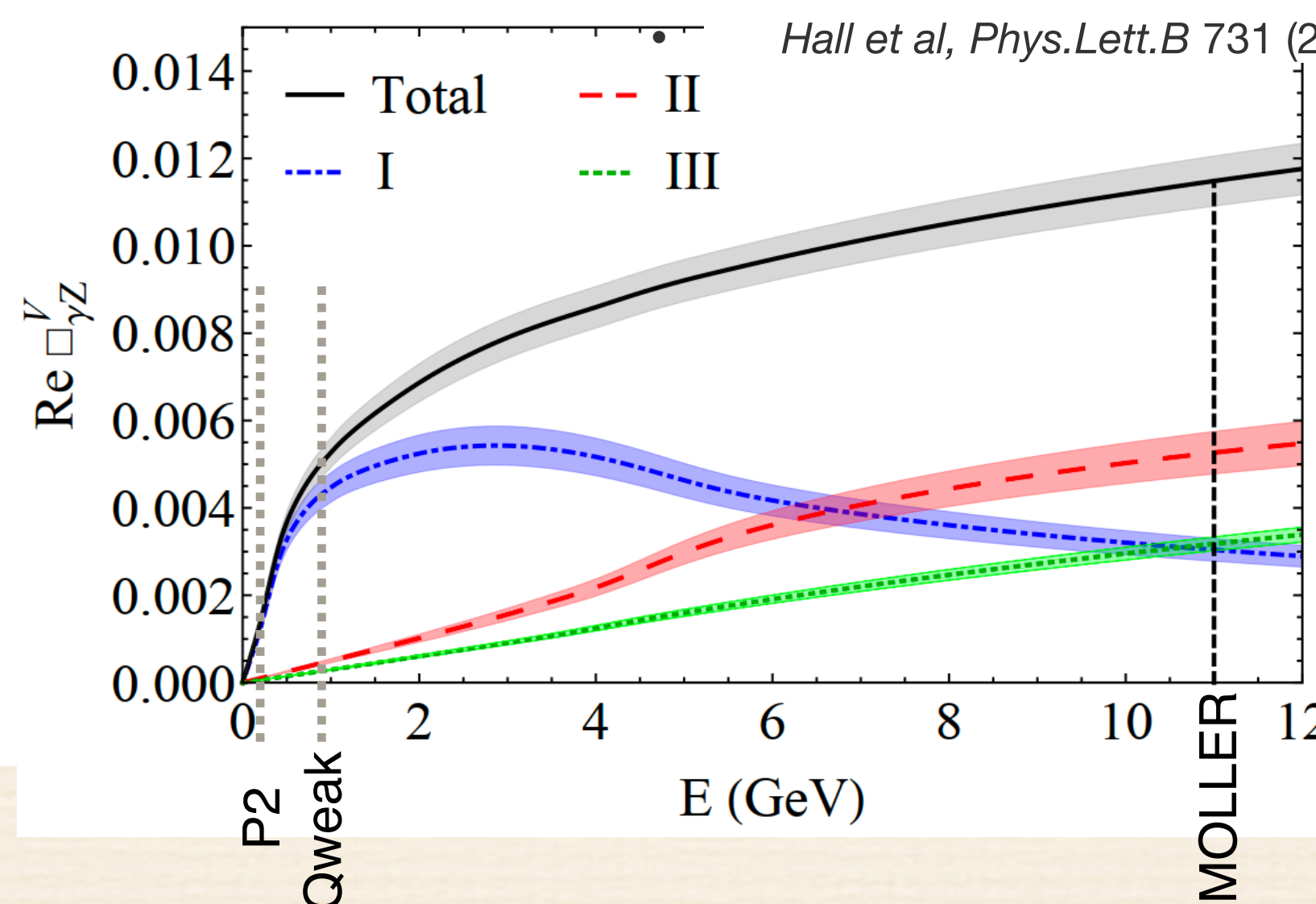

Hall et al, Phys.Lett.B 731 (2014) 287-292, Phys.Lett.B 733 (2014)

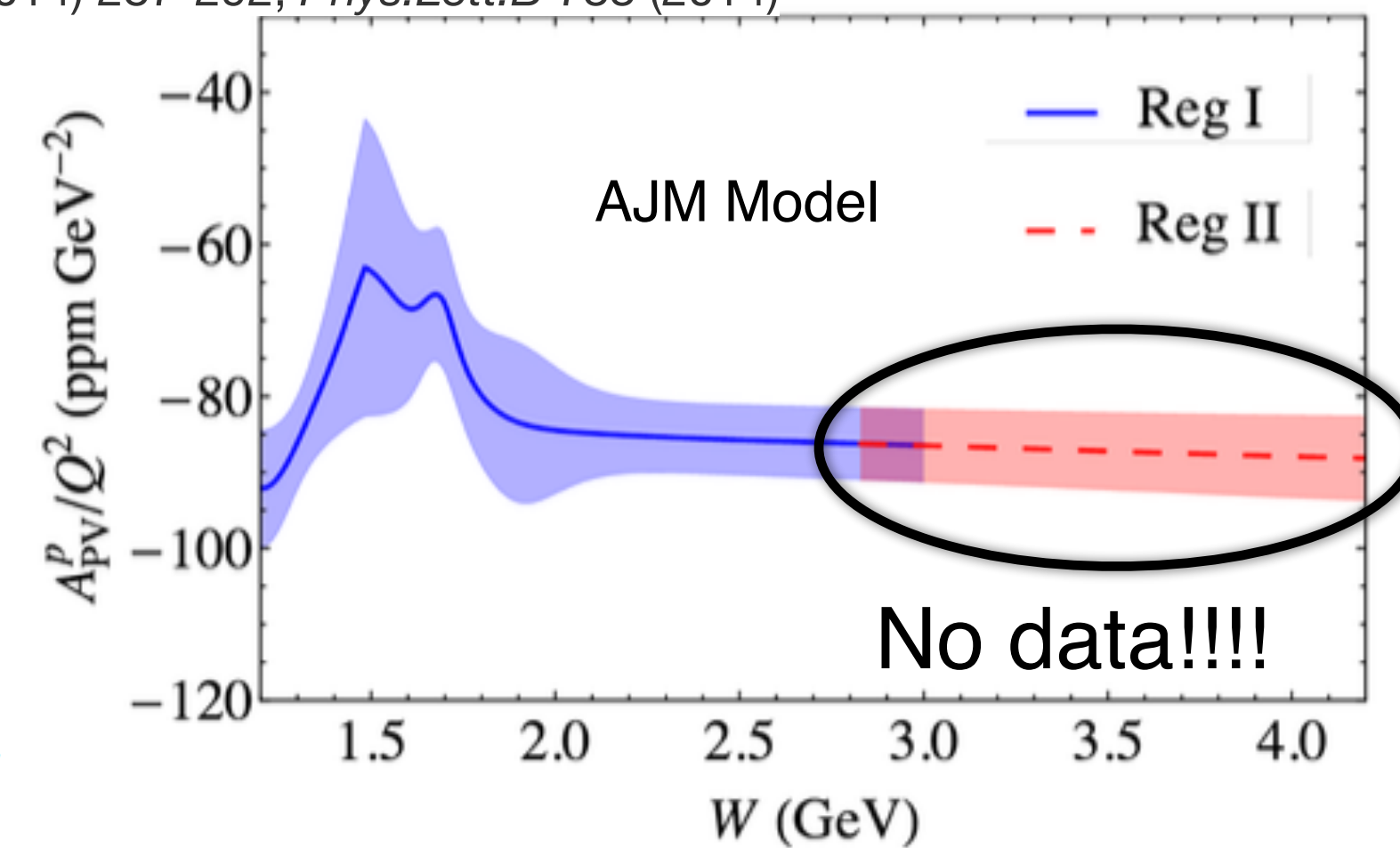

There is no data on $F_1^{\gamma Z}$ in Region II! MOLLER will make the first ever measurement!

Take Away Message

Summary

- ◆ Unique probe of TeV-scale purely leptonic interactions: beyond LEP-200
- ◆ There is also sensitivity to lepton number violation (doubly-charged scalar exchange) and to dark Z bosons (P2 is also sensitive)
- ◆ If the current schedule is maintained (US DOE funding for JLab must continue to be healthy), then we could publish an **E158-level result by summer 2028**, and reach our ultimate sensitivity by 2030 ($\pm 0.00023 \pm 0.00012$)
- ◆ The STATISTICAL uncertainty is dominant; uncertainty goal is better than current LHC pdf uncertainty for weak mixing angle
- ◆ From this workshop:
 - ★ Plan for MOLLER A_{PV} prediction at $\sim 0.2\%$
 - ★ Assistance in evaluating prediction for specific experimental acceptance/resolution
 - ★ Take note of B_n : both precision Møller scattering and new information on e-p elastic and inelastic scattering