



Open Quantum Systems: Dissipation and Decoherence from Subatomic to Cosmic Scales
Mainz Institute for Theoretical Physics, Johannes Gutenberg University Mainz, Apr 13 – 30, 2026

Supernova Neutrinos on Quantum Computers

Sajad Abbar
Max-Planck-Institut für Physik

In collaboration with Georg Raffelt, Hans-Thomas Janka, & Luigi Iapichino

Core-Collapse Supernova

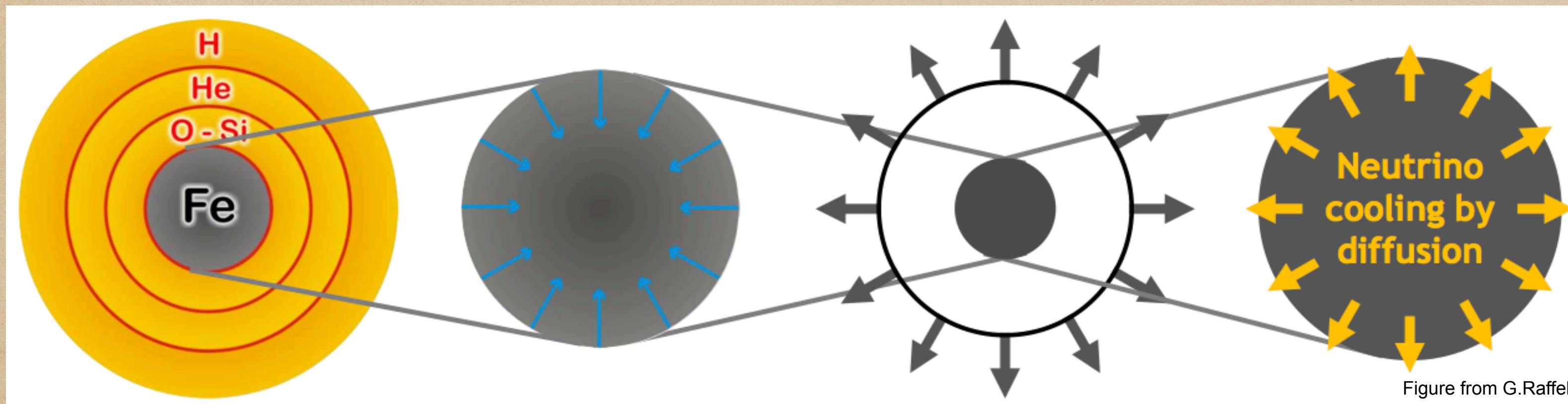

Figure from G.Raffelt

Stars burn lighter elements into heavier ones until the core reaches **Iron**.

When the mass of the core becomes larger than the **Chandrasekhar** mass the collapse starts.

The collapse is **halted** when the inner core reaches density of order nuclear density.

Neutrinos are trapped inside the **neutrinosphere**.

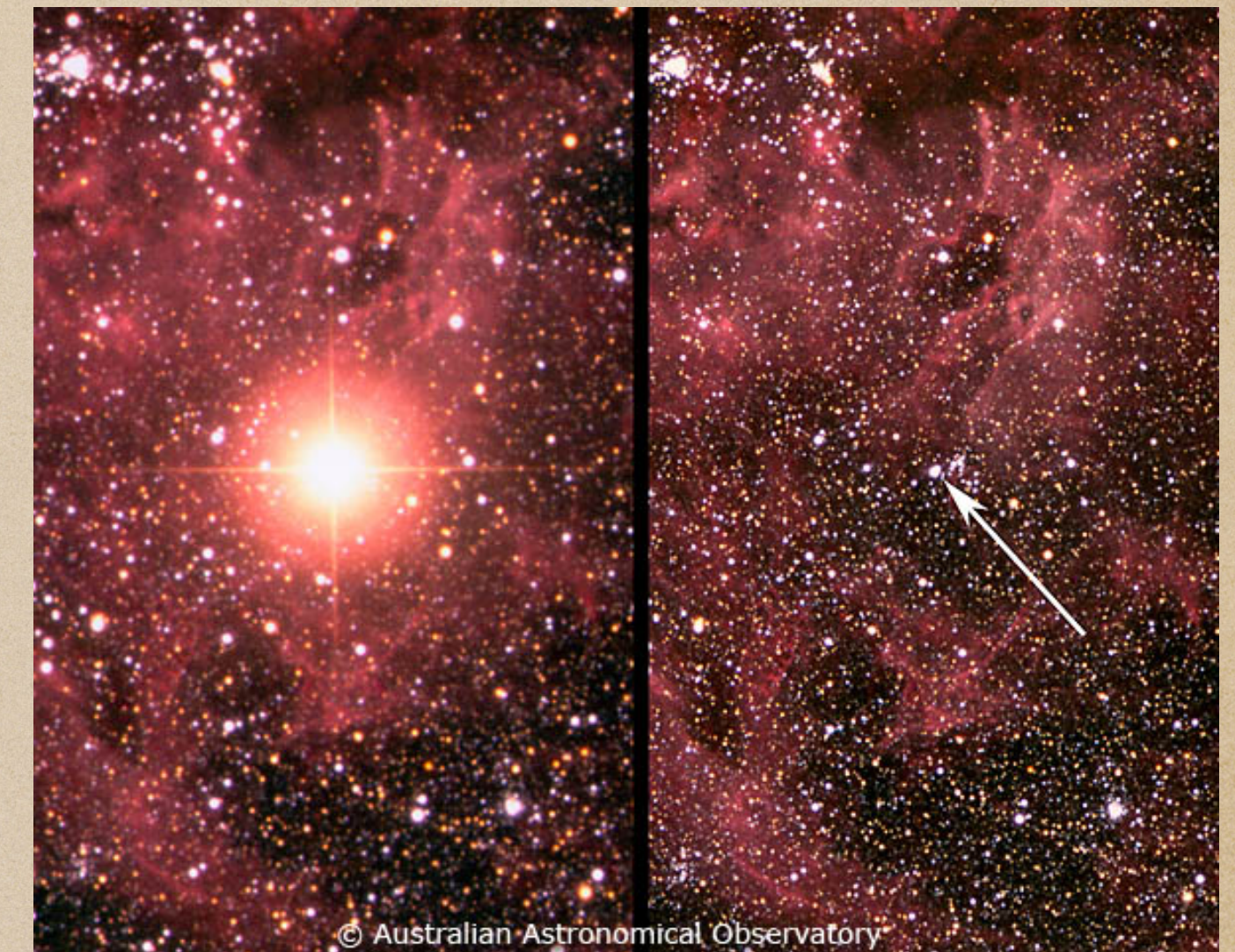

Supernova 1987A in the Large Magellanic Cloud

- A huge amount of energy is released in the form of **neutrinos** of all flavors.
- The explosion can **outshine** the host galaxy.
- Similarly **neutron star mergers** are also very dense in neutrinos.

Neutrino Flavor Conversions in Core-Collapse Supernovae

- Neutrino flavor oscillations in CCSNe is a very **rich** and **non-linear** phenomenon:

Collective Neutrino Oscillations

- Neutrino flavor conversion is crucial to **supernova dynamics!**
- Production of **heavy elements** could be very sensitive to neutrino flavor conversions.
- Understanding neutrino flavor conversion is important to analyze the **neutrino signal**.

$$i(\partial_t + \mathbf{v} \cdot \nabla)\rho = [H, \rho]$$

$$H = \frac{1}{2} \begin{bmatrix} -\omega \cos 2\theta + \sqrt{2}G_F n_e & \omega \sin 2\theta \\ \omega \sin 2\theta & \omega \cos 2\theta - \sqrt{2}G_F n_e \end{bmatrix} + H_{\nu\nu}$$

$$\sqrt{2}G_F \int d^3q (1 - \mathbf{v}_p \cdot \mathbf{v}_q)(\rho_\nu - \rho_{\bar{\nu}})$$

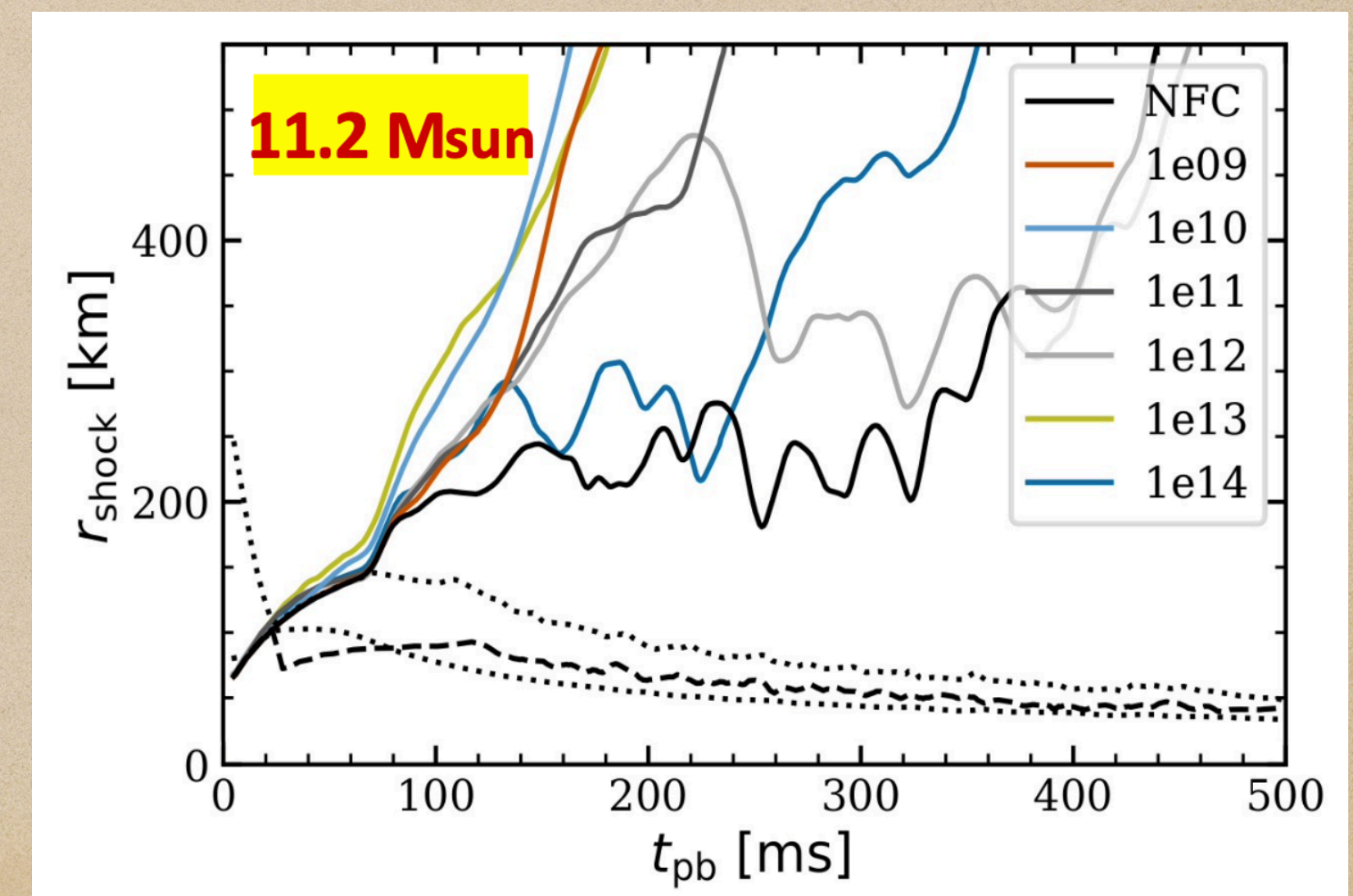

Ehring+, Phys. Rev. Lett. 131 (2023) 061401

Neutrino Flavor Conversions in Core-Collapse Supernovae

- In the mean-field approximation:

$$i(\partial_t + \mathbf{v} \cdot \nabla)\rho = [H, \rho]$$

$$H = \frac{1}{2} \begin{bmatrix} -\omega \cos 2\theta + \sqrt{2}G_F n_e & \omega \sin 2\theta \\ \omega \sin 2\theta & \omega \cos 2\theta - \sqrt{2}G_F n_e \end{bmatrix} + H_{\nu\nu}$$

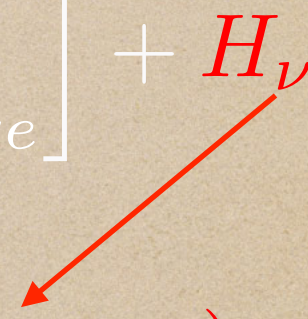
$$\sqrt{2}G_F \int d^3q (1 - \mathbf{v}_p \cdot \mathbf{v}_q)(\rho_\nu - \rho_{\bar{\nu}})$$

- Probing **beyond mean-field** approximation: multi-body correlations in the neutrino gas.

Collective Neutrino Oscillations on Quantum Computers

- It can be modelled exactly within the full **many-body** picture.

$$H = H^\nu + H^{\nu\nu} = \sum_i \mathbf{b} \cdot \boldsymbol{\sigma}^{(i)} + \frac{1}{N} \sum_{i < j} J_{ij} \boldsymbol{\sigma}^{(i)} \cdot \boldsymbol{\sigma}^{(j)},$$

$$J_{ij} = \sqrt{2} G_F \rho_\nu (1 - \cos \theta_{ij}),$$

$$\mathbf{b} = \frac{\Delta m^2}{4E} [\sin(2\theta_\nu), 0, -\cos(2\theta_\nu)],$$

- H is **linear** in the many-body picture!
- This is an **all-to-all** problem!
- The size of problem increases exponentially with N!
- This is exactly where **quantum computers** can help!

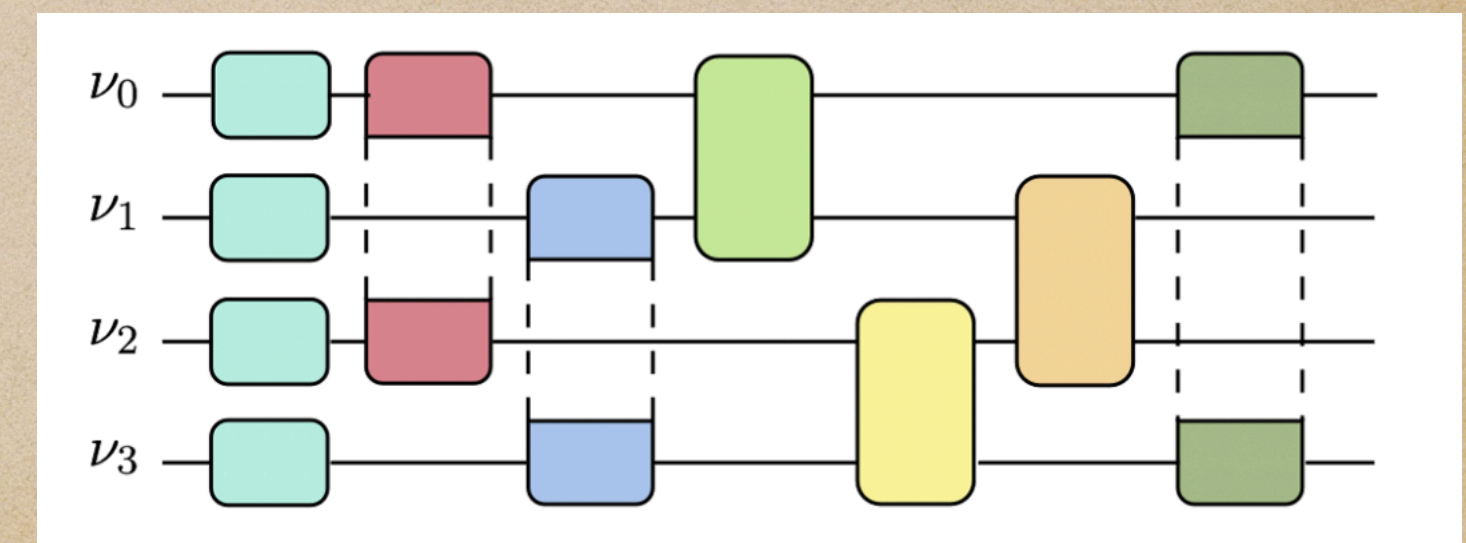

Collective Neutrino Oscillations on Quantum Computers

- Trotterization error:

$$H = H^\nu + H^{\nu\nu} = \sum_i \mathbf{b} \cdot \boldsymbol{\sigma}^{(i)} + \frac{1}{N} \sum_{i < j} J_{ij} \boldsymbol{\sigma}^{(i)} \cdot \boldsymbol{\sigma}^{(j)},$$

Trotter error

$$e^{A+B} \neq e^A e^B$$

- Quantum computers are limited in their native gates!

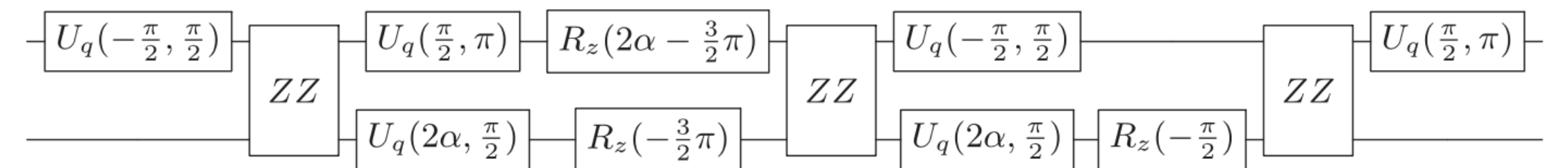

- Not all the qubits are connected!

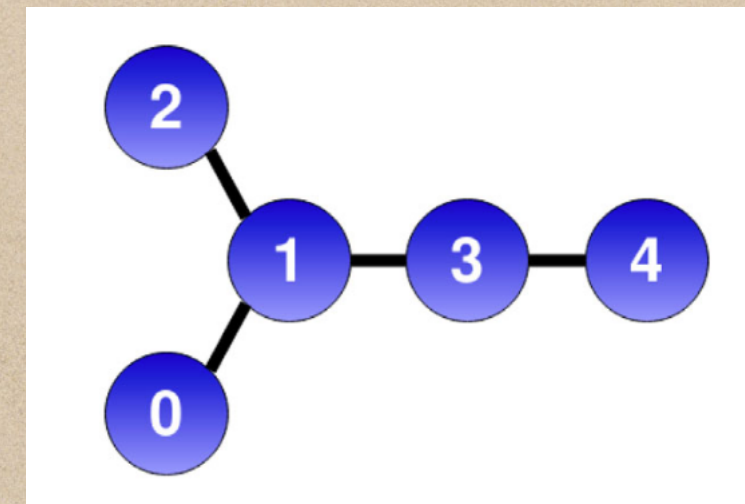

- We are living in the NISQ (Noisy Intermediate-Scale Quantum) era

Collective Neutrino Oscillations on Quantum Computers

Hall et. Al; PRD (2021)

Aydeniz et. al.; Quantum Information Processing (2022)

Siwach et. al.; PRD (2023)

.....

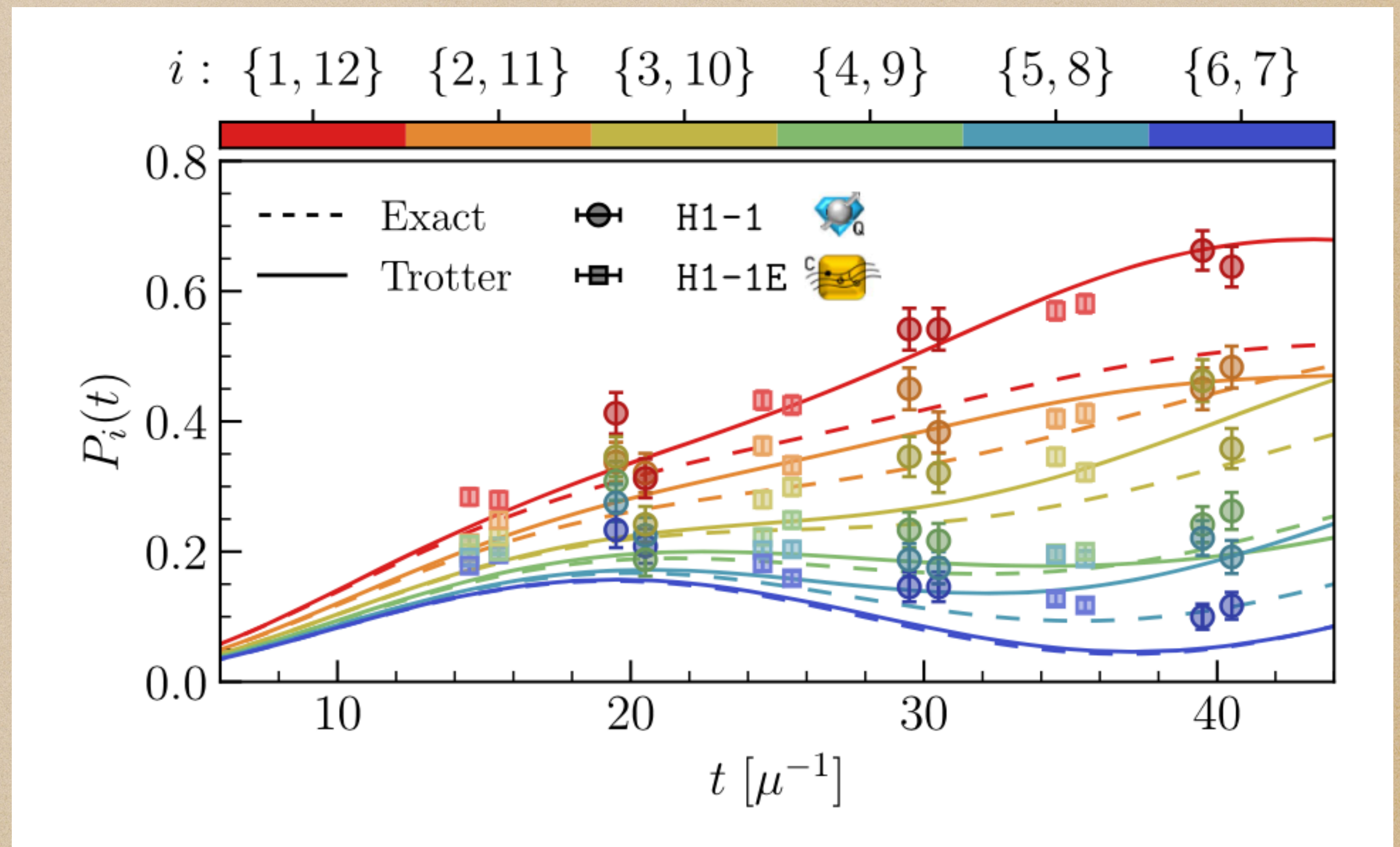

Marc Illa and Martin J. Savage; PRL (2023)

Hybrid Quantum-Classical Approach

- We choose a trial wavefunction:

$$|\Psi(\vec{\theta}(t))\rangle$$

- McLachlan's EoM:

$$M(\vec{\theta}) \dot{\vec{\theta}} = V(\vec{\theta})$$

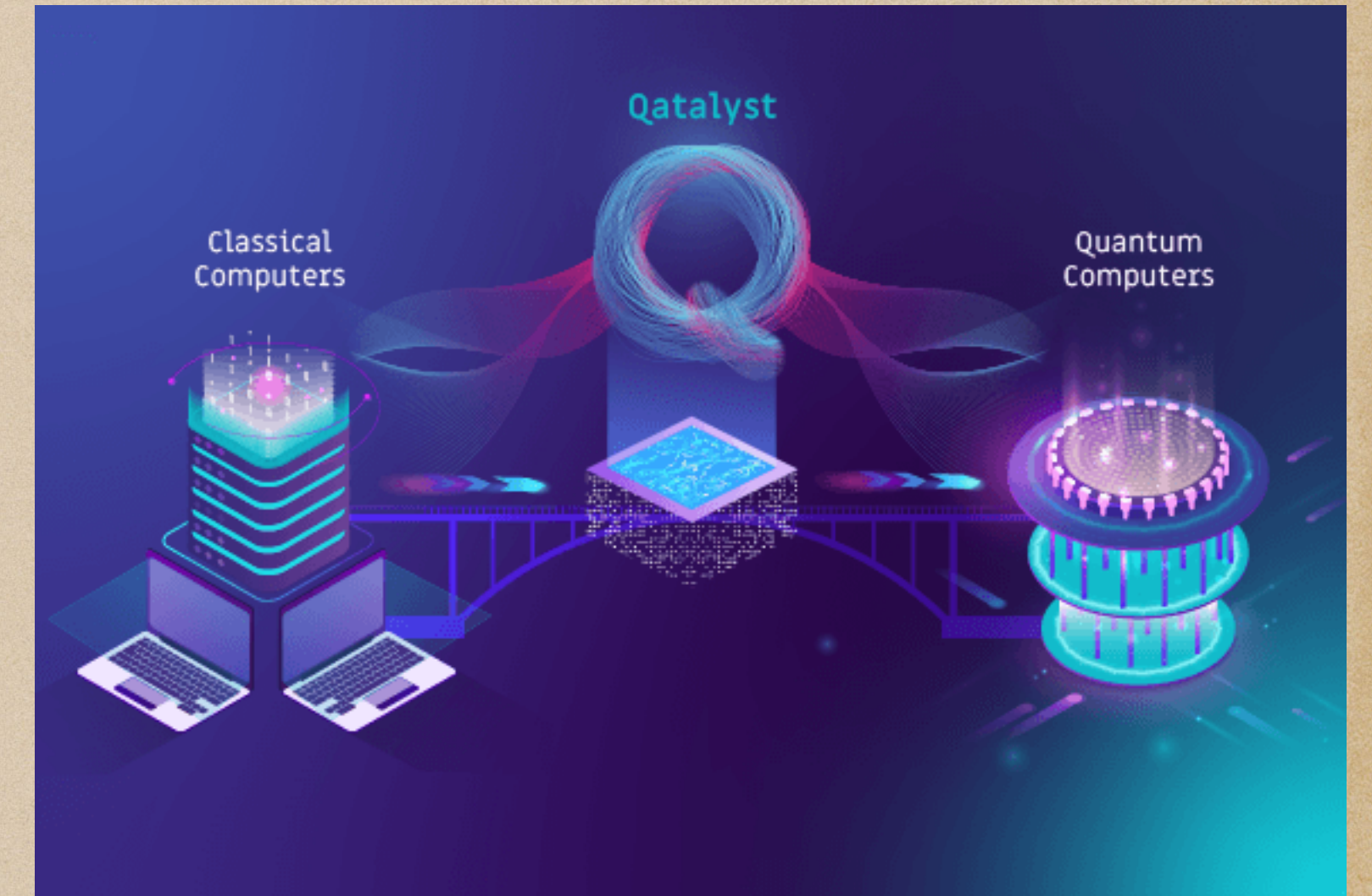

$$M_{ij} \sim \langle \partial_i \Psi | \partial_j \Psi \rangle$$

$$V_i \sim \langle \partial_i \Psi | H | \Psi \rangle$$

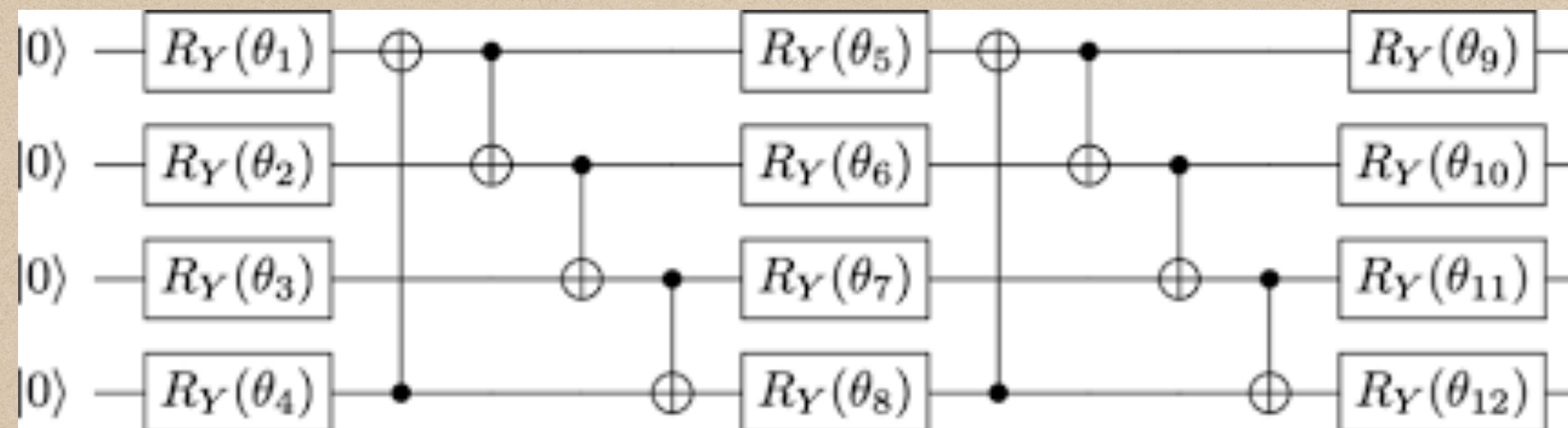

- M and V components can be calculated on QC, then $\dot{\vec{\theta}}$ can be solved on HPC devices.

Hybrid Quantum-Classical Approach

- Hybrid methods can help with the **circuit depth and coherence time** by being local.
- In Hybrid methods, there is **no Trotterization error!**
- One can use hardware native gates to prepare the Ansatz.
- **All-to-all** connectivity could be circumvented.

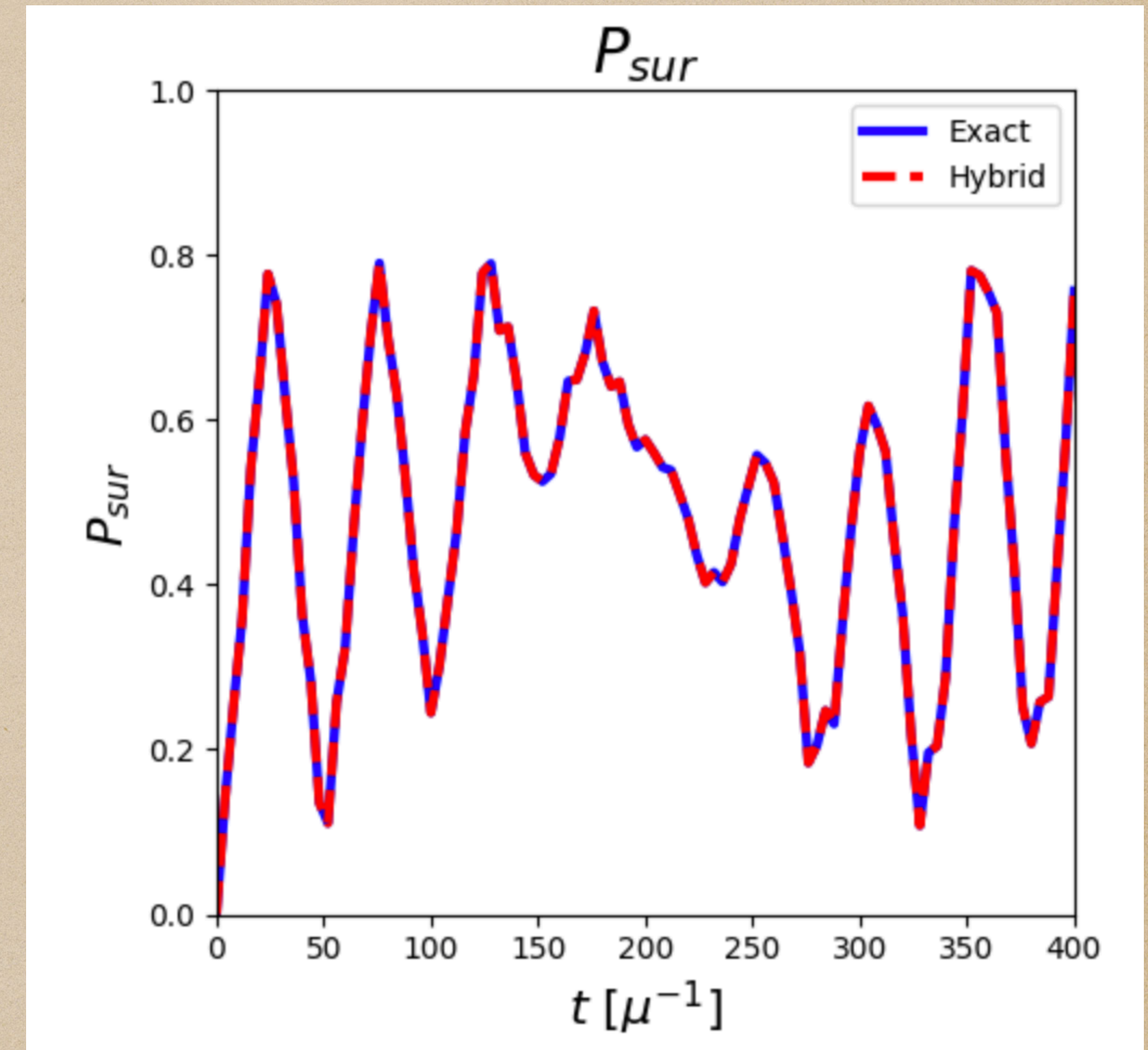

Collective Neutrino Oscillations on Quantum Computers

- Our projects have been selected for the pilot phase of two of Europe's most advanced quantum computing systems at the LRZ.
- **Euro-Q-Exa**: a 54-qubit superconducting quantum computer system inaugurated just in March. It is tightly integrated with supercomputers for hybrid workflows
- **MAQCS (planqc)**: 1000-qubit device based on neutral atom technology; all-to-all connectivity!



Summary

- Core-collapse supernovae and neutron star mergers are very dense in neutrinos.
- Neutrino flavor conversions is very different in such environments.
- Quantum computers can be used to study this problem in many-body picture.
- Hybrid could help in a number of ways!

Thank you!

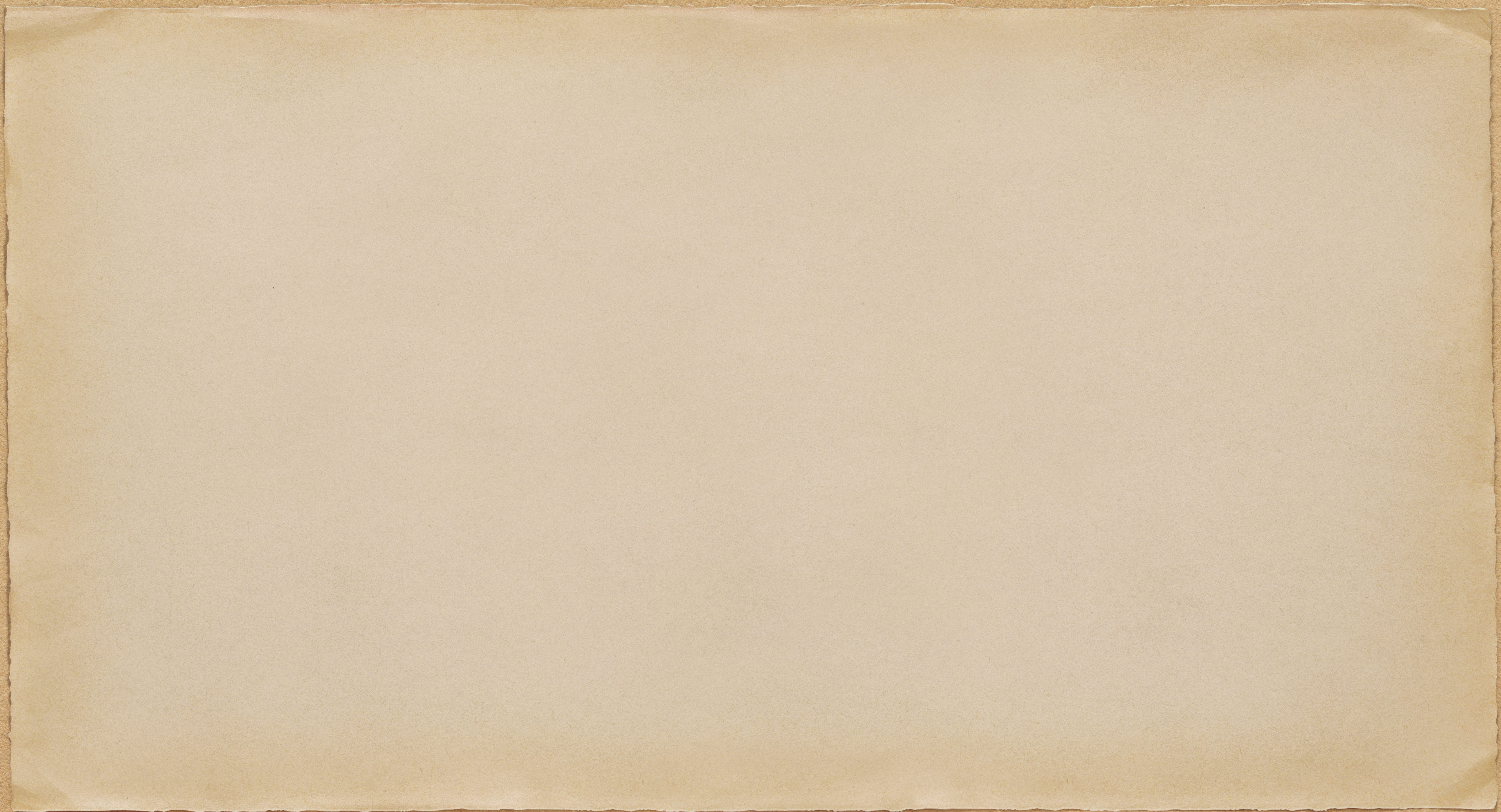

Generative AI for Supernova Neutrinos

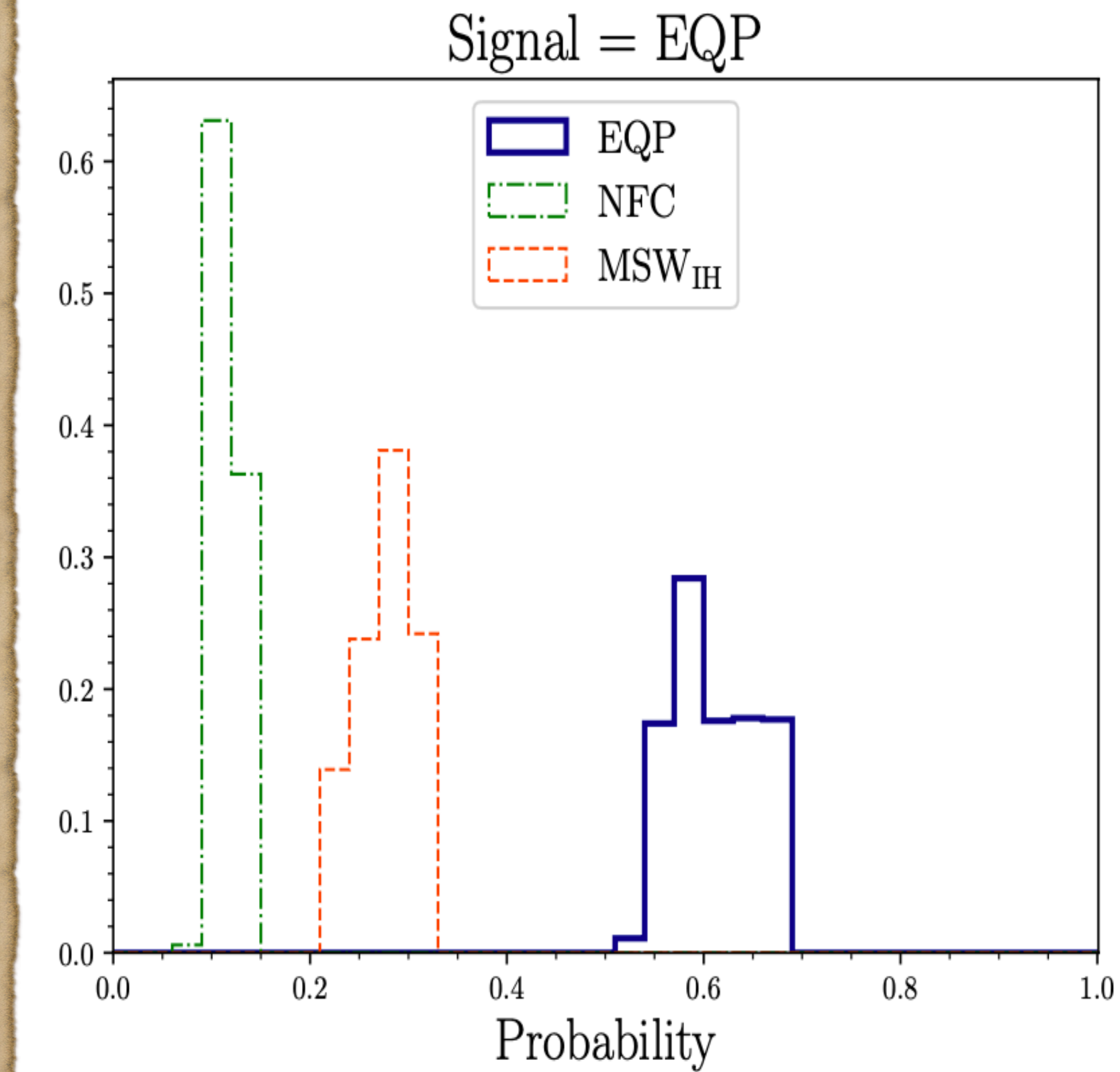
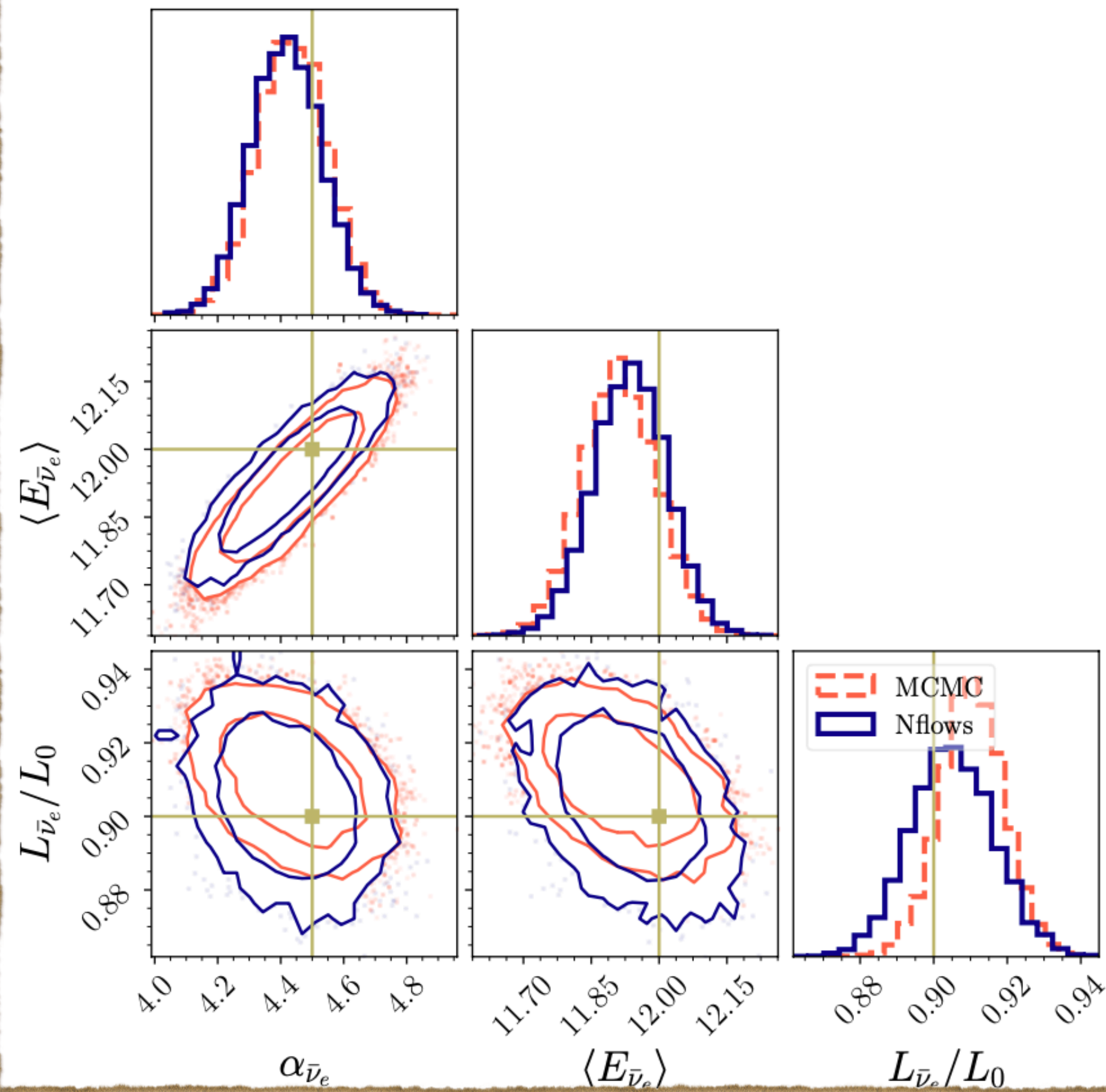

Ana Roshan (Master)

Abbar, to be submitted

Generative AI

- **Generative AI** creates synthetic but realistic outputs!
- In Generative AI, we try to model a probability distribution.

Discriminative AI

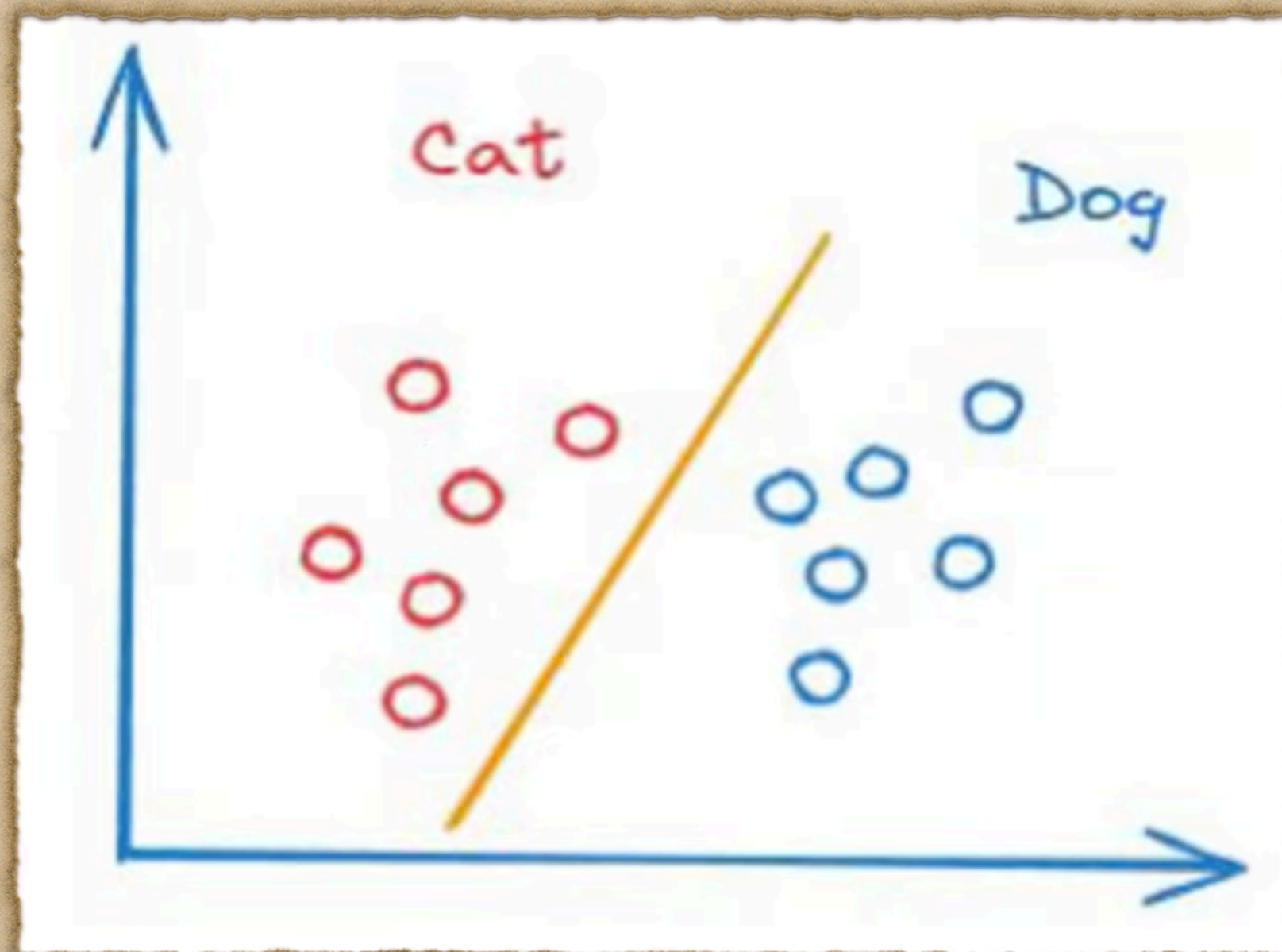

$$P(y|x)$$

Generative AI

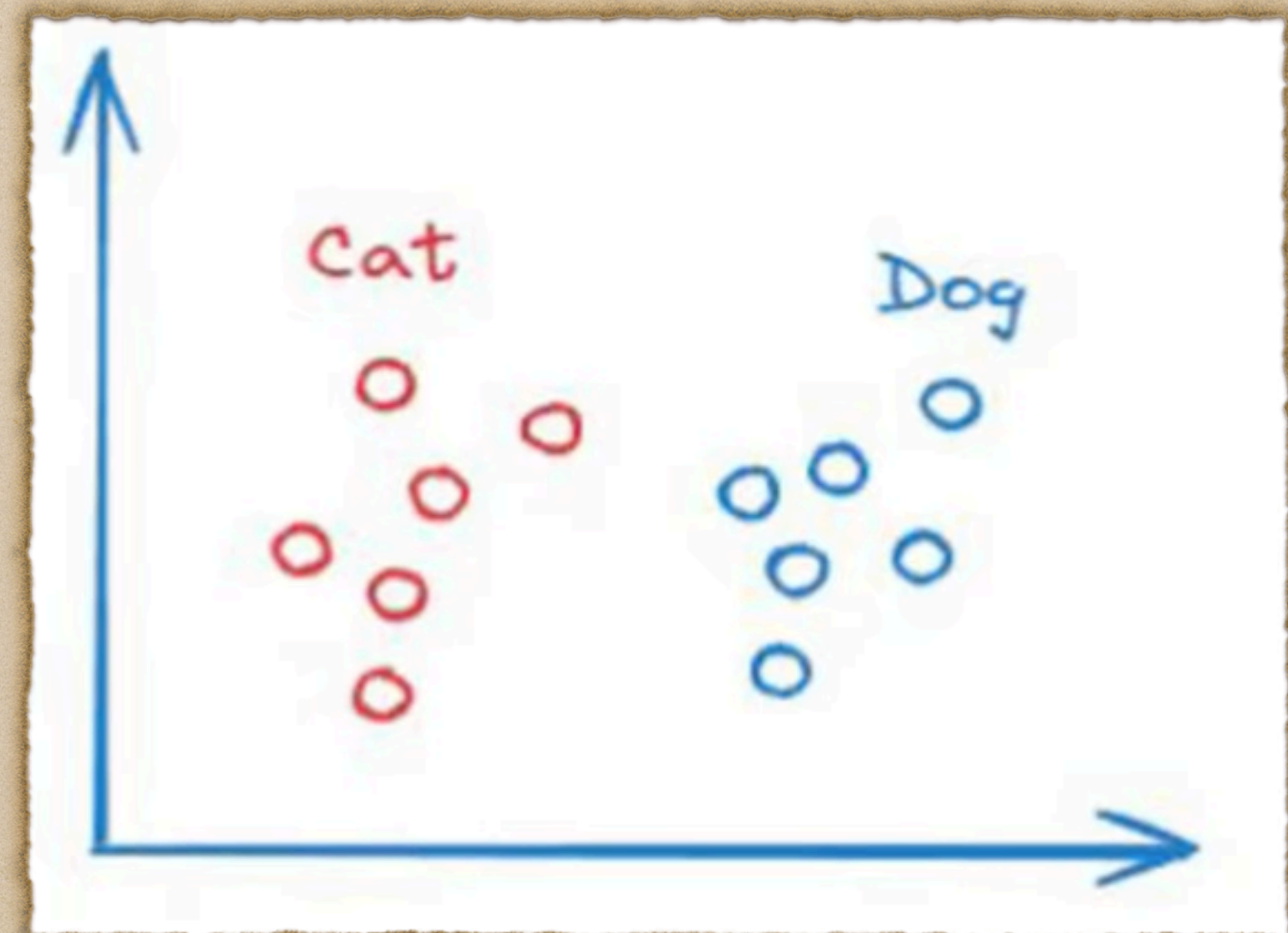

$$P(x)$$

Supernovae Neutrino Spectra

Based on Hudepohl et al. 2010

- Nontrivial: what are the spectral parameters given the event distribution at the detector?
- Mathematically speaking, we want to calculate $P(\text{parameters})$
- Traditionally one would use MCMC
- AI has transformed this field:
Generative AI

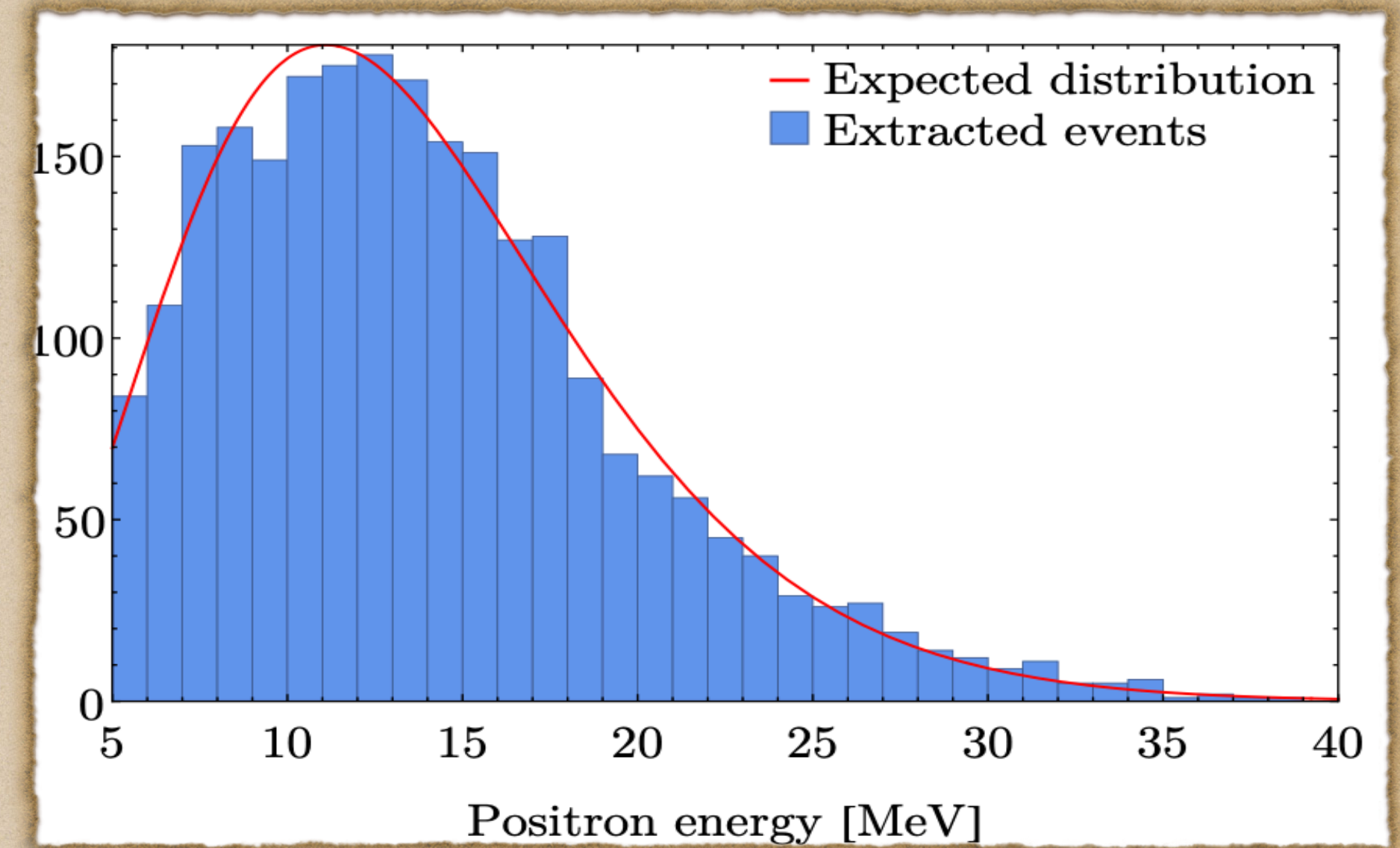

Rosso et al. 2018

Generative AI for SN neutrinos

Abbar, to be submitted

- We used generative AI for measuring spectral parameters, assuming IBD channel at SK.

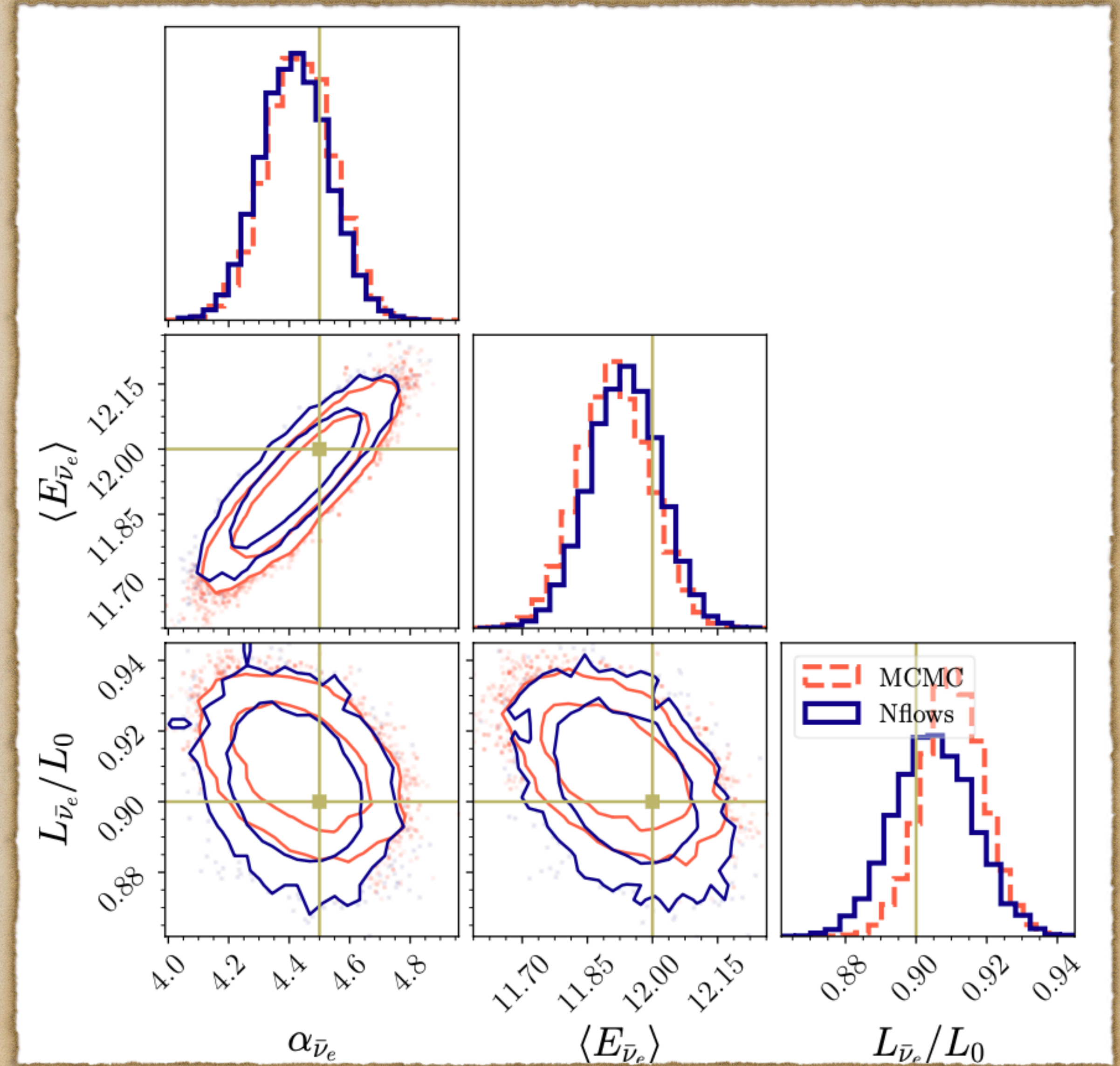

Generative AI for SN neutrinos

Abbar, to be submitted

- We also Bayesian neural networks to classify neutrino flavor conversion scenarios.

