

Universität
Münster

Background mitigation in xenon-based rare-event search experiments

Bormio International Winter Meeting on Nuclear Physics

22 January 2026

Philipp Schulte, Lutz Althüser, Robert Braun, Volker Hannen, Christian Huhmann, David Koke, Ying-Ting Lin, Sakuntha Nirodana Prathapage, Patrick Alexander Unkhoff, Daniel Wenz, Christian Weinheimer

living.knowledge

This work is supported by the ERC AdG project
"LowRad" of C. Weinheimer (No. 101055063)



Dark matter & $0\nu\beta\beta$ searches with liquid noble gas detectors

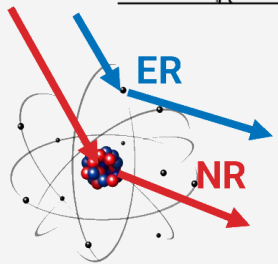
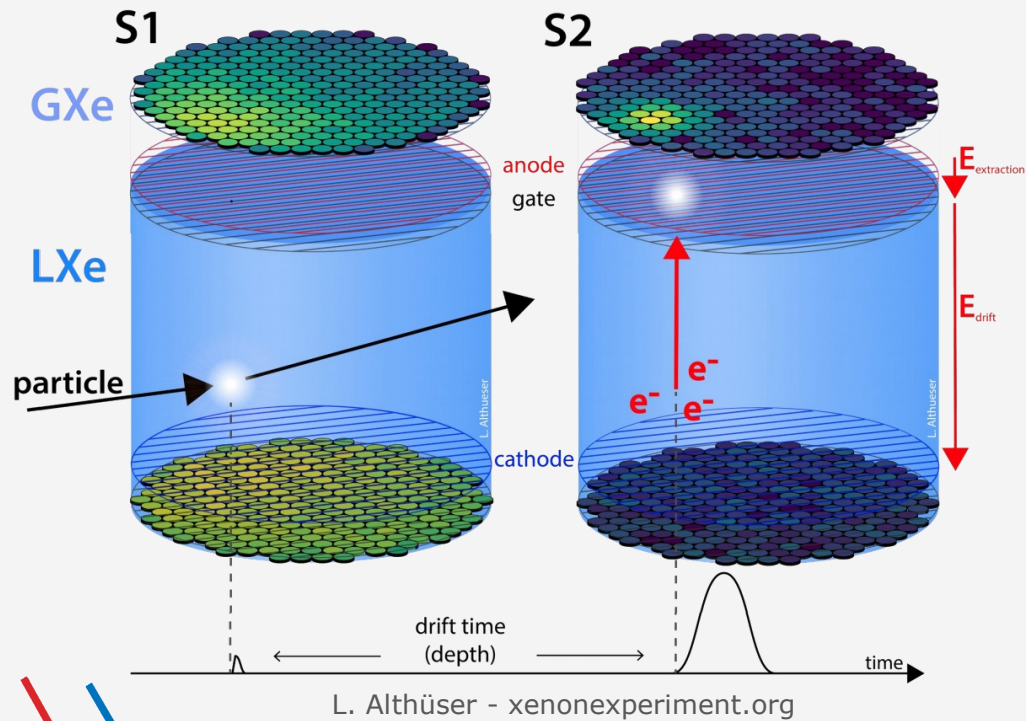

ER (Electronic Recoils) γ , β backgrounds

NR (Nuclear Recoils) WIMP signal, neutrons, CEvNs

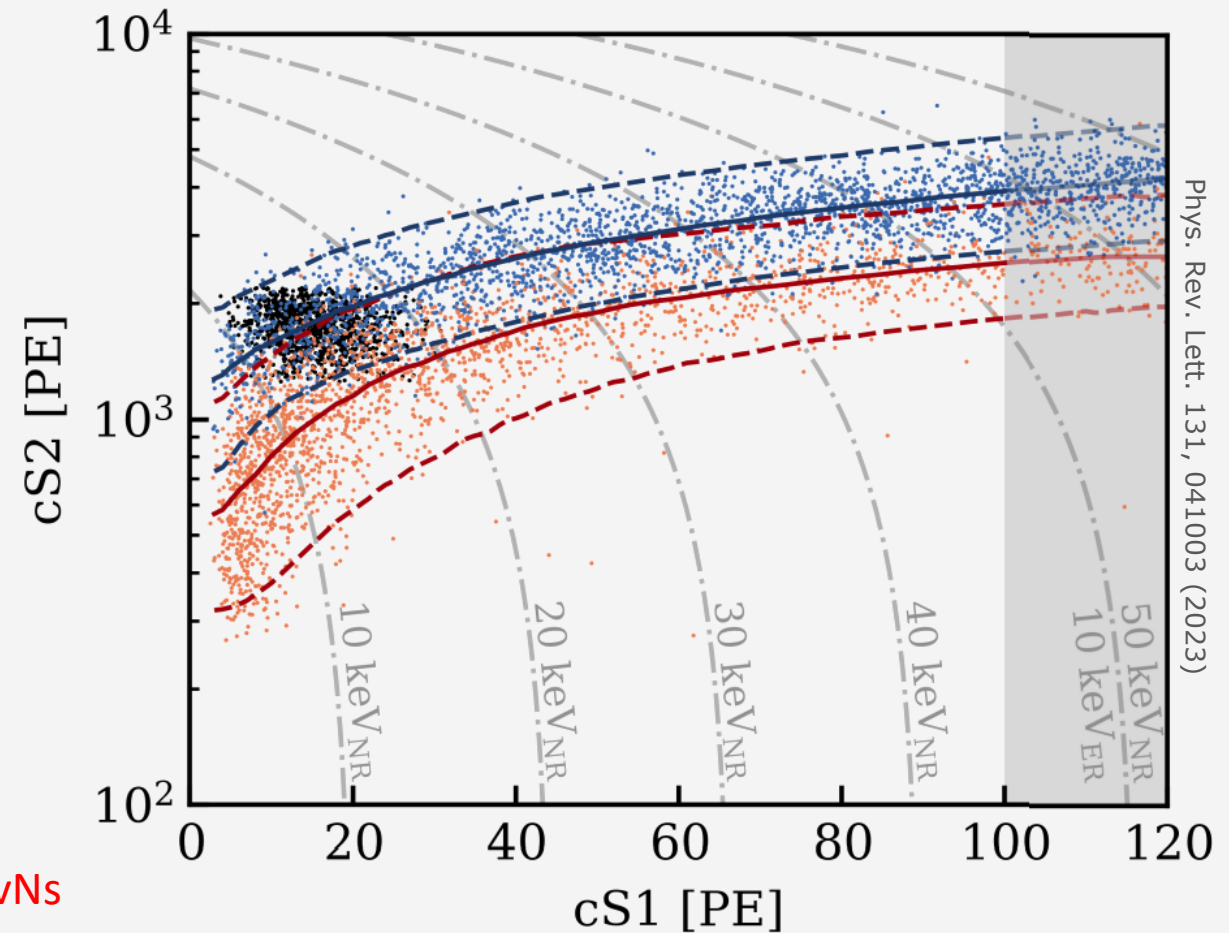

Limiting backgrounds

Expected dark matter (DM) scattering or $0\nu\beta\beta$ rate:
1-10 events per 10 t·yr → need background reduction

External backgrounds largely controlled:
Underground location, material screening, shielding
and vetoes

Remaining dominant backgrounds:
Solar neutrinos (non-shieldable)
Intrinsic noble gases:
 ^{85}Kr , ^{222}Rn +progenies, ^{37}Ar , ^{39}Ar , (^{136}Xe)

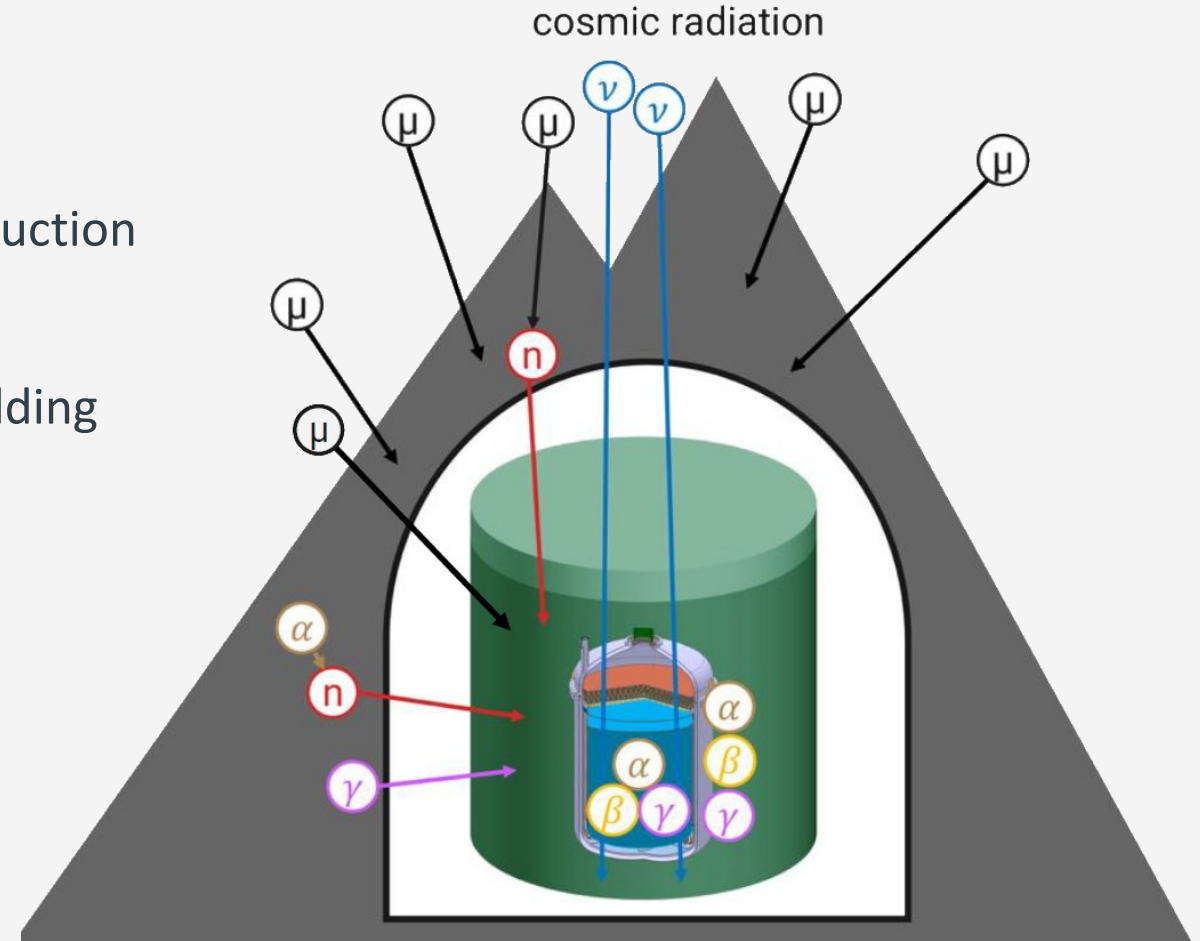

Cryogenic ^{85}Kr xenon distillation

Separation by relative volatility (vapor pressure)

Kr/Ar removal (light impurities, more volatile than Xe)

Kr (-153°C), Ar (-186°C) preferentially stay in the vapor phase

Real systems: multi-stage rectification

A packed column provides many separation stages

Needs to be removed once by krypton distillation

Kr can re-enter via tiny air leaks or during maintenance

For continuous Rn emanation \rightarrow continuous distillation

Single-stage distillation

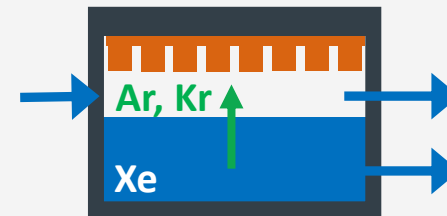

Multi-stage rectification column

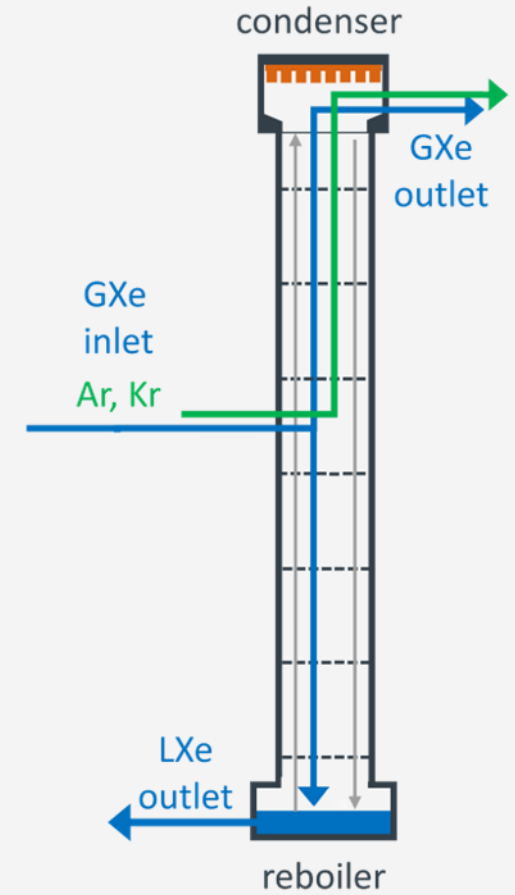

Cryogenic ^{222}Rn xenon distillation

Rn (-62°C) removal: less volatile than Xe , stays in liquid

Rn source types:

1b (GXe leaks): rate $k_{1b} \rightarrow \varepsilon$ to RRS

1a (LXe emanation): rate $k_{1a} \rightarrow$ extracted (f)

2: (enters before detector) rate k_2

For a reduction factor 2 of 1a sources:

Circulate mass with its half life (3.8 d)

$$\tau = \frac{t_{1/2}}{\ln(2)} = 5.5 \text{ d} \rightarrow \frac{8.4 \text{ t}}{132 \text{ h}} = 64 \frac{\text{kg}}{\text{h}} \approx 200 \text{ slpm}$$

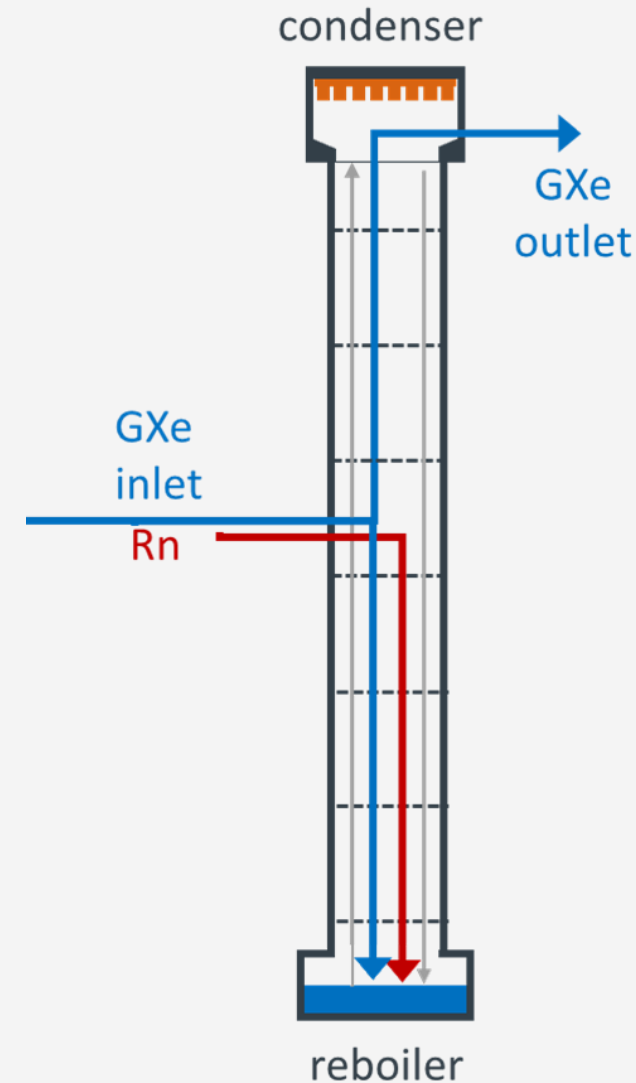

Cryogenic ^{222}Rn xenon distillation

Rn (-62°C) removal: less volatile than Xe, stays in liquid

Rn source types:

1b (GXe leaks): rate $k_{1b} \rightarrow \epsilon$ to RRS

1a (LXe emanation): rate $k_{1a} \rightarrow$ extracted (f)

2: (enters before detector) rate k_2

For a reduction factor 2 of 1a sources:

Circulate mass with its half life (3.8 d)

$$\tau = \frac{t_{1/2}}{\ln(2)} = 5.5 \text{ d} \rightarrow \frac{8.4 \text{ t}}{132 \text{ h}} = 64 \frac{\text{kg}}{\text{h}} \approx 200 \text{ slpm}$$

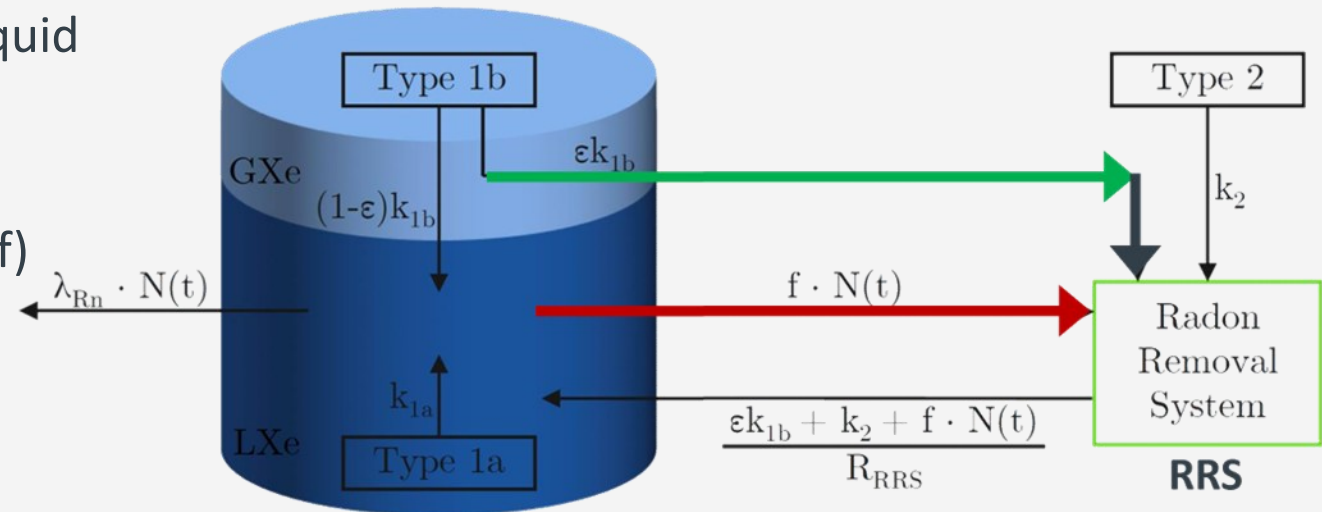

$$r(R_{\text{RRS}} \rightarrow \infty, f, \epsilon) \approx 2 \cdot 2 = 4$$

European Physical Journal C (2022) 82:104

Online cryogenic distillation in XENONnT

XENONnT operates a continuous cryogenic xenon distillation column as a radon removal system (RRS)

Radon concentration of $0.9 \mu\text{Bq}/\text{kg}^{[1]}$ (≈ 1 Rn atom per 10 mol Xe) was achieved in XENONnT using a ≈ 3.5 m tall distillation column

Challenge: Cleaned GXe must be liquefied before re-entering the detector again

→ Uses principle of a heat pump

Future dark matter detectors such as XLZD will require even lower radioactivity levels and larger target masses of $O(80 \text{ t})$

→ LowRad

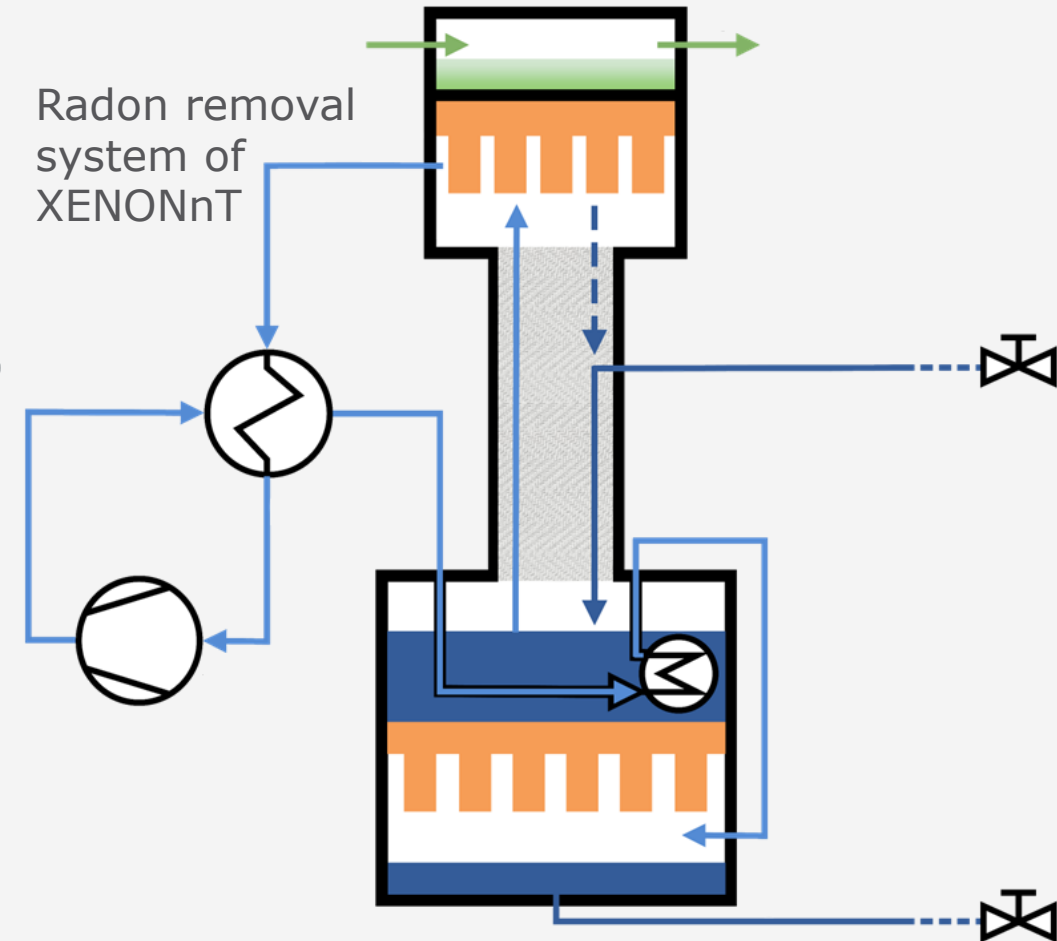

Low radon and low internal radioactivity – LowRad

ERC Advanced Grant LowRad of C. Weinheimer

Continuous online ^{85}Kr removal:

$^{\text{nat}}\text{Kr} \approx 30 \text{ ppq}$ in steady-state operation

^{222}Rn total reduction to $< 0.1 \mu\text{Bq/kg}$:

×3 via material selection + offline (β/α) tagging

Additional with passive approaches: surface coatings, hermetic TPC concepts

×6 via active removal (cryogenic distillation / RRS)

Towards an integrated “all-in-one” purification + distillation demonstrator

→ Goal: $< 1 \text{ }^{222}\text{Rn}$ atom per 160 mol Xe ($\approx 0.1 \mu\text{Bq/kg}$)

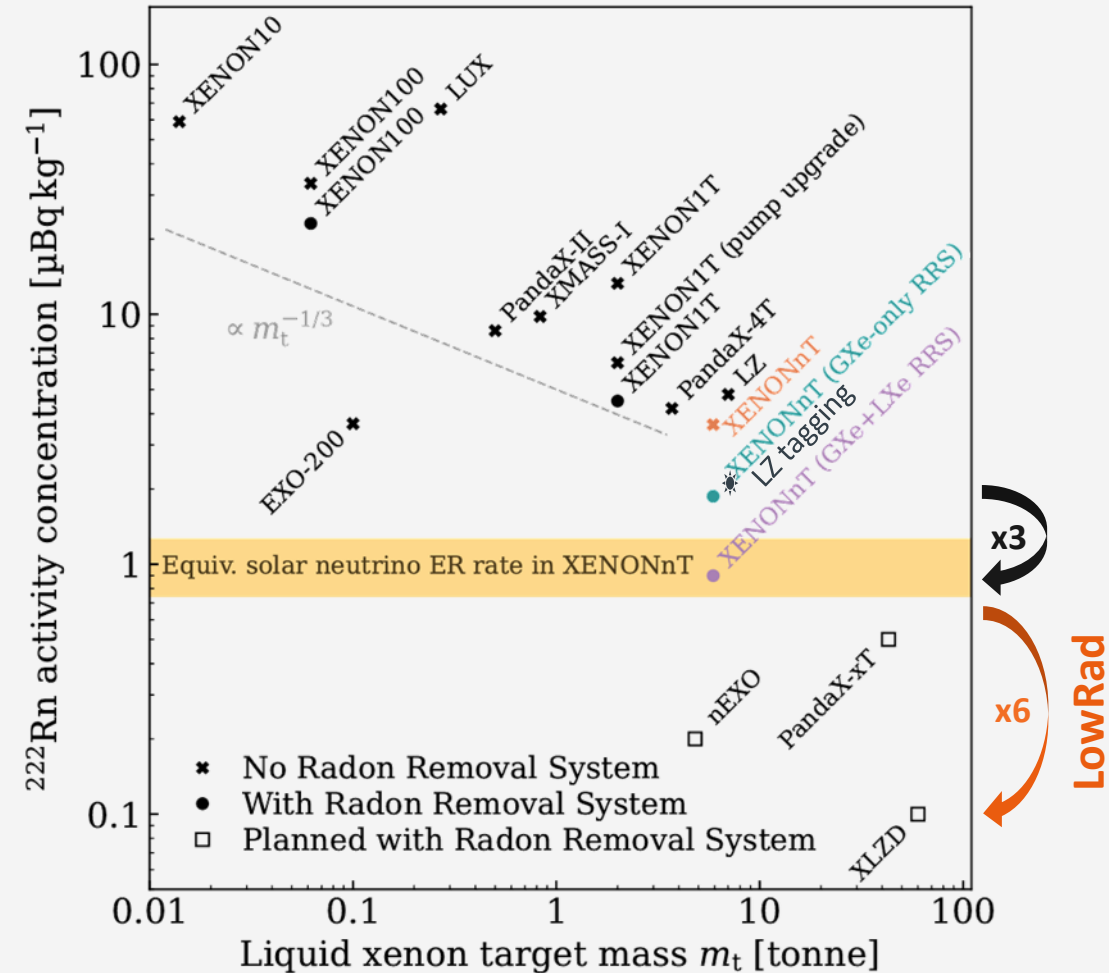

The LowRad radon distillation

XLZD target ($\approx 80\text{--}100$ t LXe, $0.1 \mu\text{Bq/kg}$)

→ RRS needs $O(60 \text{ kW})$ cooling and heating

Power of a cold head @LXe temperature: 1 kW needs $O(5\text{--}10 \text{ kW})$

Cooling by liquid nitrogen (1 kW needs 430 kg/d)

Develop a fully functional, hermetically separated xenon heat pump to reduce external cryogenic cooling demand

Radon decay detector integrated into the distillation column

→ Provides ^{222}Rn removal verification in operation

→ Enables in-situ radon emanation measurements

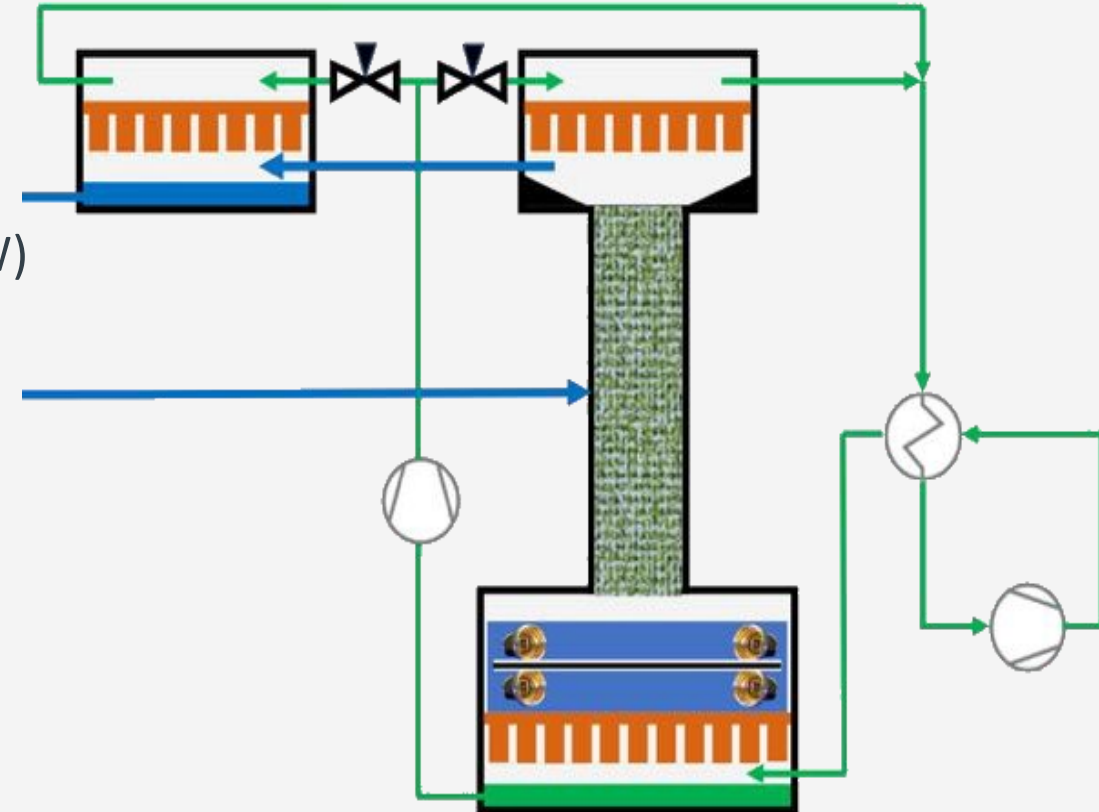

Xenon heat pump idea

The idea is a closed Clausius-Rankine cycle using xenon as working fluid to drive the new distillation column

Condenser around $-78\text{ }^{\circ}\text{C}$, evaporator around $-108\text{ }^{\circ}\text{C}$ with xenon pressures near 4.3 bar and 1 bar

Heating power is supplied to the column bottom, cooling power to the column top by circulating xenon

Small heat-pump proof-of-concept setup as an intermediate step towards a full distillation column

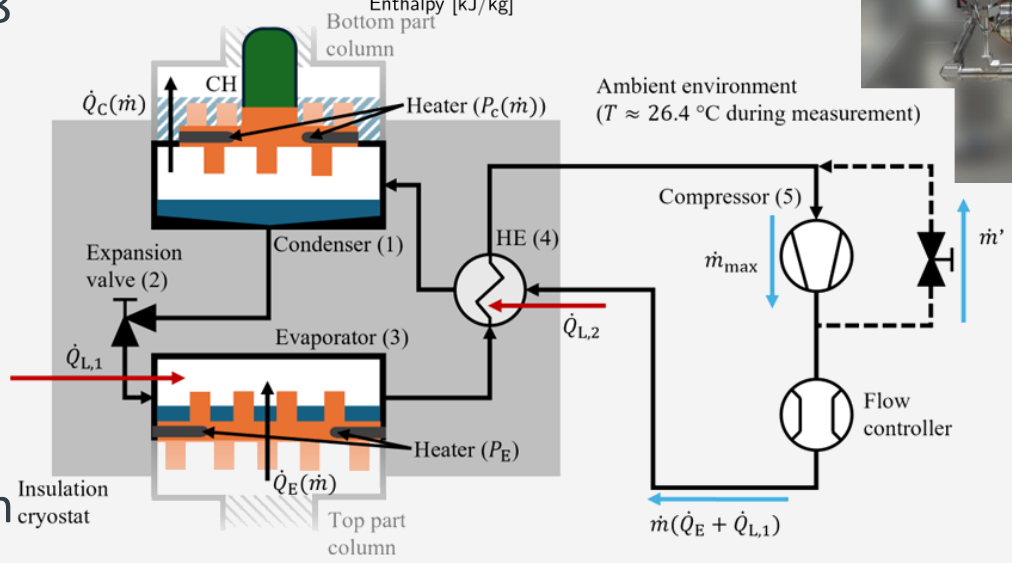
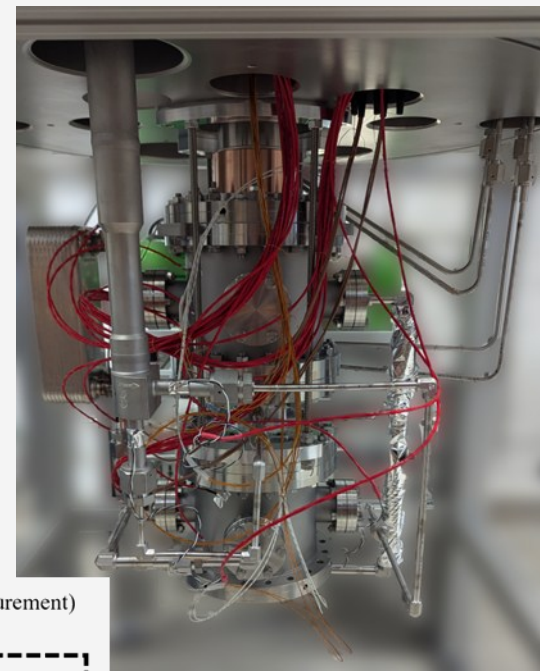
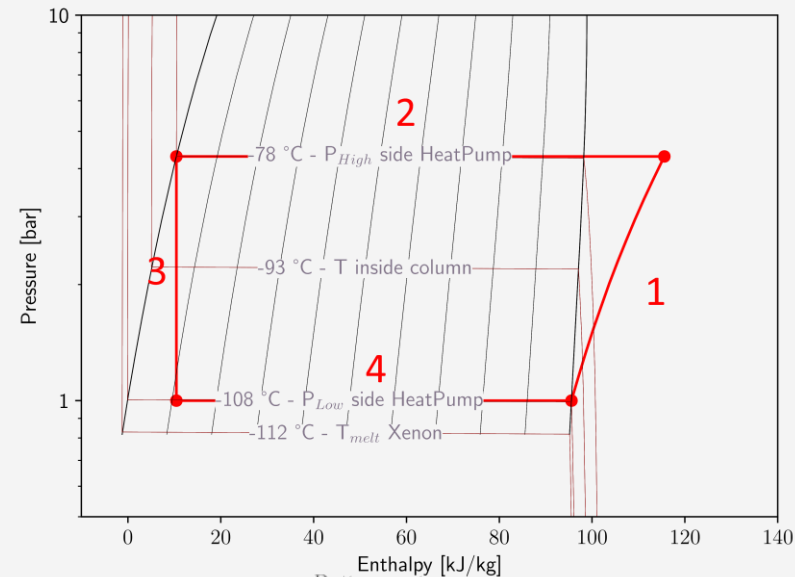

Demonstration measurements

Two measurement campaigns

Evaporator heat load varied between 0 and 130 W

Pressures and temperatures reach steady state for each heat load

Liquid level stable within ± 2 mm

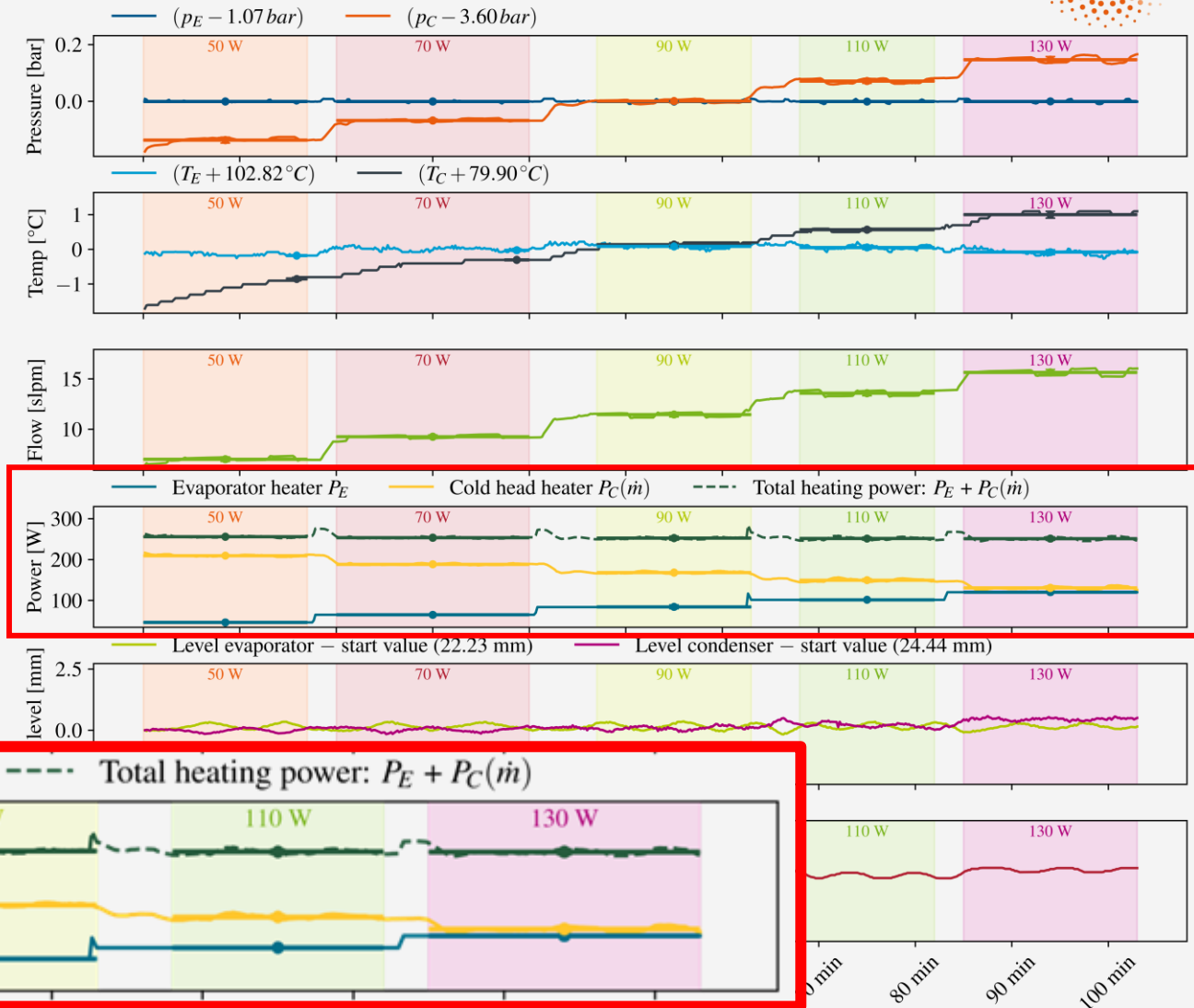

Heating and cooling power

Cooling and heating powers derived from enthalpy $h(p,T)$:
 Scales linearly with xenon mass flow

Results:

Cooling: (121 ± 7) W

Heating: (117 ± 7) W

Flow: (14.9 ± 0.2) slpm

Measured $\text{COP}_{\text{Cooling}} \approx 0.30 \pm 0.01$ at design point ($P_{\text{el}} \approx (386 \pm 1)$ W)
 $\rightarrow \approx 10\%$ of the ideal $\text{COP}_{\text{Cooling}} = 3$

Main limitation: inefficient xenon compressor and extra pressure losses

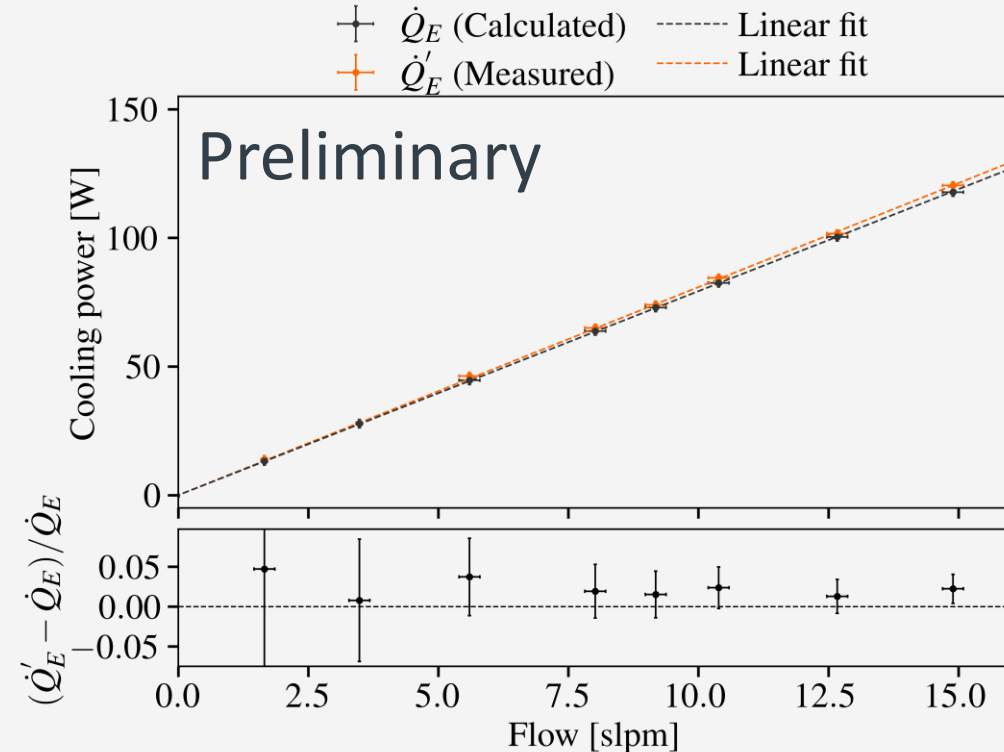

arXiv:2511.05172v2

Other LowRad Projects

Krypton concentrator

High separation at off-gas fraction $\sim 10^{-3}$ (flows < 5 slpm)

3 m column

2.2 m packing height

Ongoing: map off-gas fraction vs flow (RGA measurements)

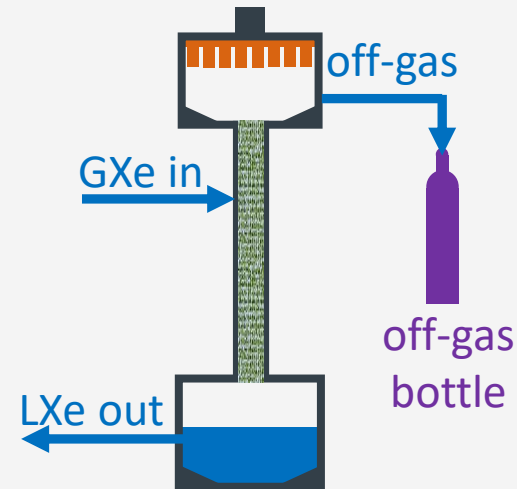

Compact all-in-one purification

Instrumented LXe detector volume

Combined GXe/LXe purification & monitoring

High-flow LXe distribution testbed

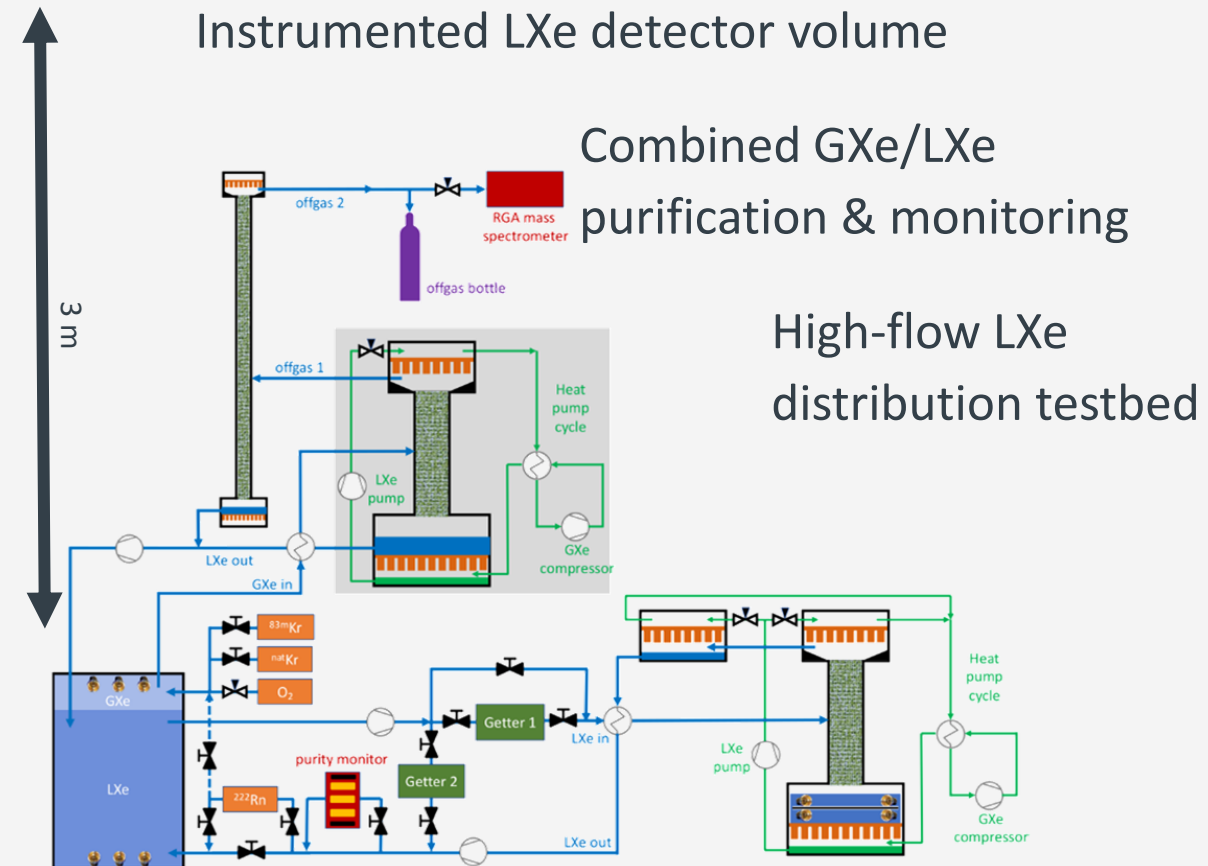

Summary and Outlook

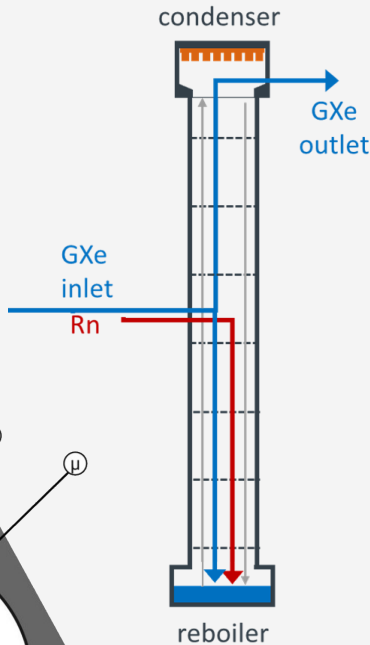
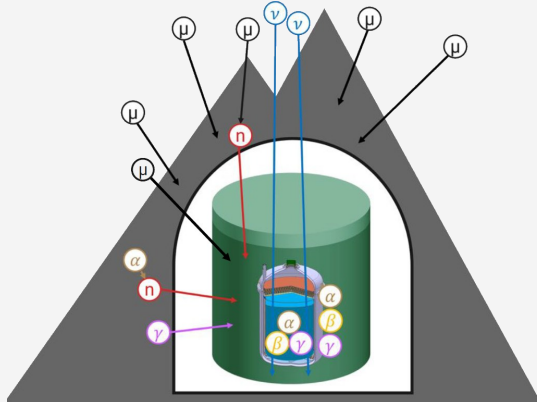
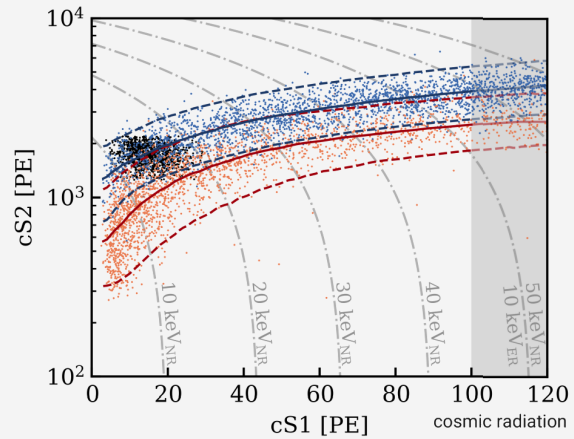

Proof-of-concept

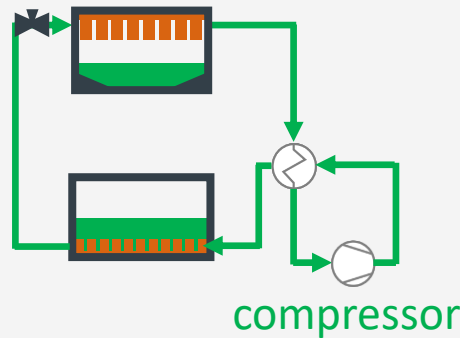

First results:

Cooling: (121 ± 7) W

Heating: (117 ± 7) W

Flow: (14.9 ± 0.2) slpm

$COP_{cool} \approx 0.30 \pm 0.01$

→ Technology demonstration successful → now scaling and optimizations

Radon distillation prototype

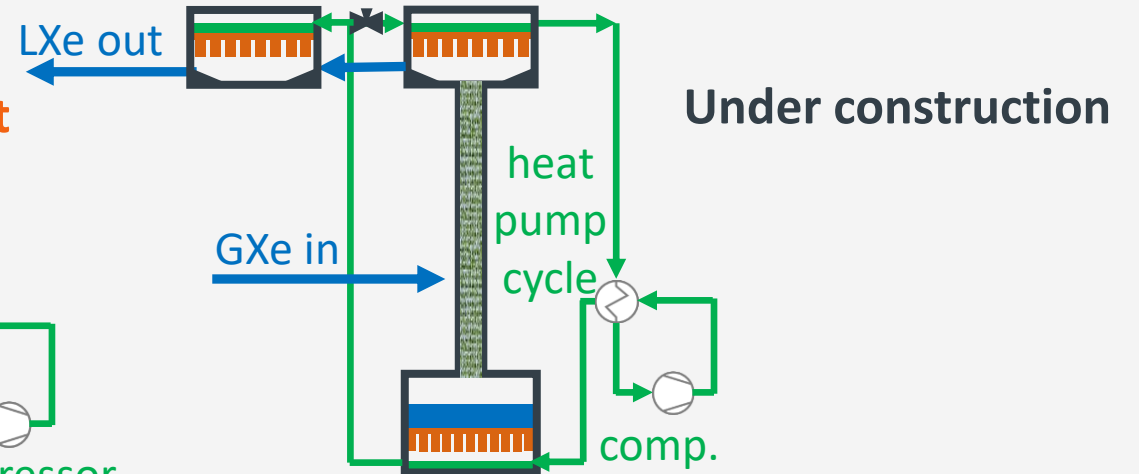

Scaling to XLZD

